

KOBELCO

HYDRAULIC CRAWLER CRANE

CK850-III

Max. Lifting Capacity: 85 US Tons

Max. Boom Length: 200 ft

Max. Boom + Jib Length: 180 ft + 60 ft

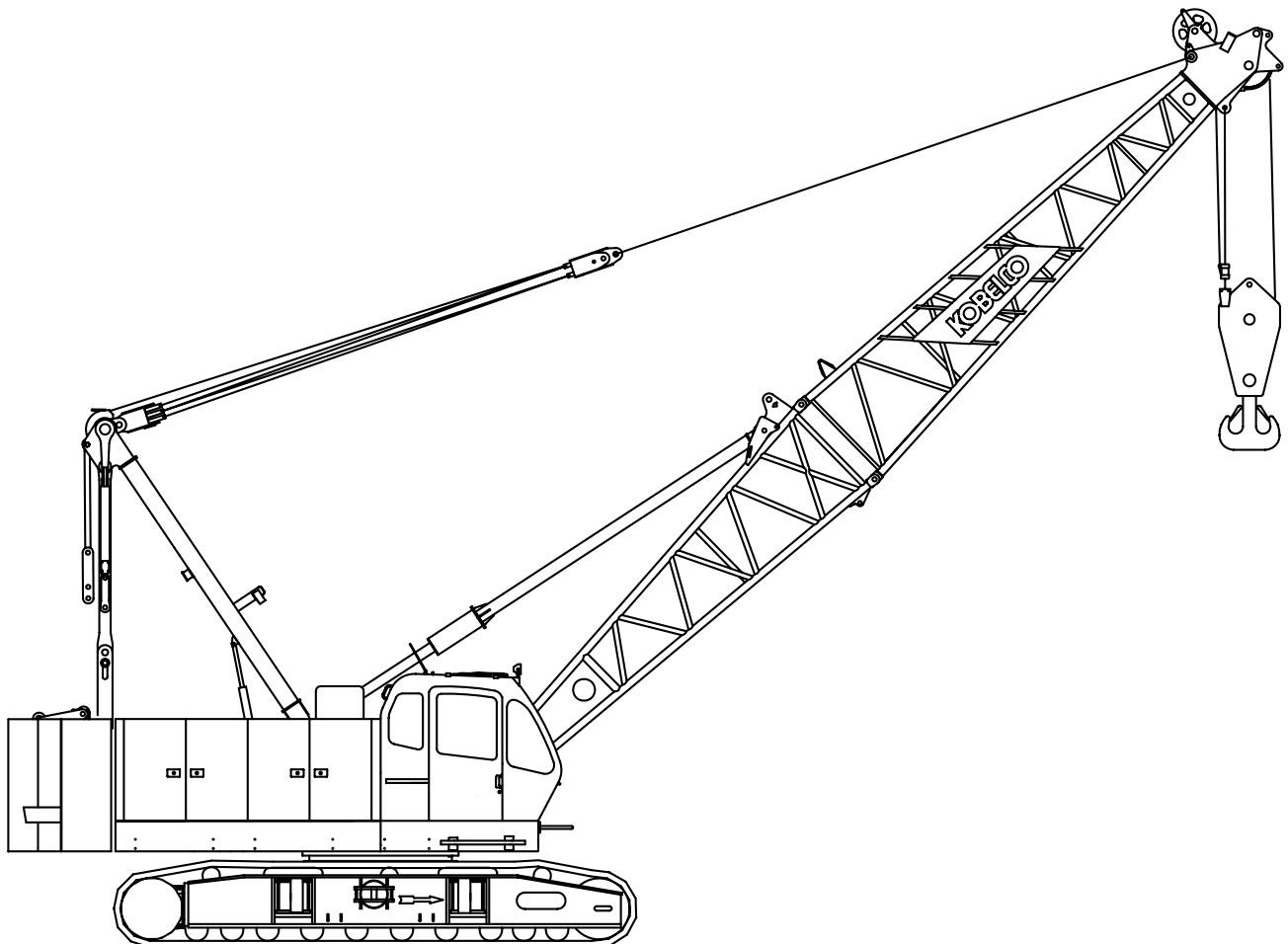

SPECIFICATIONS FOR CK850-III CRAWLER CRANE

The Kobelco CK850-III Crawler Crane is designed from the ground up for reliable operation, convenient maintenance and easy transport. Please consult your Kobelco distributor for additional information regarding specifications, operating parameters and maintenance requirements.

1. GENERAL DESCRIPTION

Type	Crawler mounted, fully revolving
Maximum lifting capacity	170,000 lbs (77,100 kg) (at 11' operating radius, with 40' boom)
Basic boom length	40' (12.2 m)
Maximum boom length	200' (61.0 m)
Basic boom & jib length	80' + 30' (24.4 m + 9.1 m)
Maximum boom & jib length	180' + 60' (54.9 m + 18.3 m)
Working weight	Approx. 162,700 lbs (73,800 kg)
Ground bearing pressure	Approx. 11.2 psi (77.1 kPa)
Gradeability	40 %

Calculations to determine working weight, ground pressure and gradeability include the weight of the upper and lower works of the crane, counterweights and carbody weights, 40' boom and hook block.

2. GENERAL DIMENSIONS

Height to top of gantry (lowered)	11' 4" (3.45 m)
Width of upper machine with operator's cab	10' 6" (3.20 m)
Radius of rear end (counterweight)	14' 1" (4.28 m)
Counterweight ground clearance	3' 7" (1.10 m)
Center of rotation to boom foot pin	3' 7" (1.10 m)
Height from ground to boom foot pin	5' 9" (1.75 m)
Height over gantry (raised)	20' 3" (6.18 m)
Overall length of crawler	19' 8" (5.99 m)
Center to center of tumblers	16' 10" (5.13 m)
Overall width of crawlers	16' 3" (4.94 m)
Shoe width	36" (0.91 m)
Ground clearance of carbody	15" (0.39 m)

3. WORKING SPEED

Hoist line speed (front and rear drum)	390 ~ 10 ft/min (120 ~ 3 m/min)
Lowering line speed (front and rear drum)	390 ~ 10 ft/min (120 ~ 3 m/min)
Boom hoist line speed	230 ~ 7 ft/min (70 ~ 2 m/min)
Boom lowering line speed	230 ~ 7 ft/min (70 ~ 2 m/min)
Swing speed	4.0 rpm (4.0 min ⁻¹)

Travel speed (High / Low)

1.18 / 0.75 mph (1.9 / 1.2 km/hour)

Line speed based on single line, no load and first layer of rope on the drum. Line speed is controllable by Dial-type Speed Control System.

4. UPPER MACHINERY

4.1 Power plant

Diesel engine, make and model

Hino J08E-TM (Comply with EPA "Tier 3")

No. of cylinders 6

Bore X stroke 4-13/32" X 5-1/8" (112 mm X 130 mm)

Cycles 4

Total displacement 469 cu.in (7,684 cm³)

Rated output SAE GROSS

213 HP / 2,000 rpm (159 kW / 2,000 min⁻¹)

Maximum torque

588 lbs-ft / 1,600 rpm (797 Nm / 1,600 min⁻¹)

Starter 24 Volts / 5.0 kW

Alternator 24 Volts / 60 Amp

Batteries

Two 12 volt, 136 AH capacity series connected.

Radiator

Corrugated type core, thermostatically controlled.

Throttle

Twist grip type hand throttle, electrically controlled.

Air cleaner Dry type with replaceable paper element.

Fuel tank capacity 106 US gal. (400 liters)

Lube oil filter

Full flow and by-pass type with spin off type cartridge.

Fuel filter Heavy duty with spin off type cartridge.

Approximate fuel consumption

0.342 lb / HP-hr (208 g / kW-hr)

10.53 US gal. / hr at 100 % HP

4.2 Hydraulic pumps

All driven from heavy duty pump drive.

Load hoist, boom hoist and propel 2 Piston pumps

Swing 1 Piston pump

Control system and auxiliary 2 Gear pumps

Break cooling system 2 Gear pumps

4.3 Counterweight and carbody weight

Counterweight (A)	1 x 27,340 lbs (12,400 kg)
Counterweight (B)	1 x 27,560 lbs (12,500 kg)
Total weight	54,900 lbs (24,900 kg)
Carbody weight	2 x 7,360 lbs (3,340 kg)
Total weight	14,720 lbs (6,680 kg)

4.4 Gantry

This high folding type gantry is fitted with a sheave frame for boom hoist reeving. Hydraulic lift is standard. It provides full up, full down positions with linkage.

4.5 Operator's cab

Totally enclosed from weather, this full-vision cab has safety glass all around. The adjustable, high-backed seat with armrest is standard, allowing operators to customize the position. Auxiliary controls and instruments are on a side mounted console. A signal horn, windshield wipers, air conditioner are all standard features.

4.6 Controls

At operator's right are console-mounted adjustable short levers for the front and rear drum and the boom hoist control. Beside the operator's seat on the right are two short levers for propel control, individual speed shifts for front drum, rear drum and boom drum. At the operator's left are the console mounted swing lever, knobs for front and rear drum, boom drum pawls, engine start / stop key. A swing brake control switch and signal horn button are on the swing lever.

4.7 Electric system

All wiring corded for easy serving, individual fused branch circuit.

4.8 Hydraulic system

Maximum pressure rating	4,620 psi (32.0 MPa)
Cooling	Oil to air heat exchanger
Filtration	Full flow filters with replaceable paper elements
Reservoir capacity	116 US gal. (440 liters)

4.9 Boom hoist

Powered by hydraulic motor through planetary reducer.

Drum	Single drum. Grooved for 5/8" (16.0 mm) dia. wire rope.
-------------	--

Brake

A spring set, hydraulically-released, multiple-disc holding brake is mounted inside the boom hoist motor and is operated through a counter-balance valve. An external ratchet is fitted for locking the drum.

4.10 Front drum

Powered by hydraulic motor through planetary reducer.

Drum	21.7" (550 mm) P.C.D. X 21.5" (545 mm) LG. Grooved for 7/8" (22 mm) dia. wire rope.
-------------	--

Brake

A spring set, hydraulically-released, multiple-disc holding brake is mounted inside the hoist motor and is operated through a counter-balance valve. An external ratchet is fitted for locking the drum.

Free-Fall (Standard)

Wet-type disk brake free-fall is mounted inside the drum.

4.11 Rear drum

Powered by hydraulic motor through planetary reducer.

Drum	21.7" (550 mm) P.C.D. X 21.5" (545 mm) LG. Grooved for 7/8" (22 mm) dia. wire rope.
-------------	--

Brake

A spring set, hydraulically-released, multiple-disc holding brake is mounted inside the hoist motor and is operated through a counter-balance valve. An external ratchet is fitted for locking the drum.

Free-Fall (Standard)

Wet-type disk brake free-fall is mounted inside the drum.

4.12 Third drum (Optional)

Powered by hydraulic motor through planetary reducer.

Drum	21.7" (550 mm) P.C.D. X 21.5" (545 mm) LG. Grooved for 7/8" (22.0 mm) dia. wire rope.
-------------	--

Brake

A spring set, hydraulically-released, multiple-disc holding brake is mounted inside the hoist motor and is operated through a counter-balance valve. An external ratchet is fitted for locking the drum.

Free-Fall (Standard for third drum)

Wet-type disk brake free-fall is mounted inside the drum.

4.13 Swing

Swing unit

Hydraulic motor driving through planetary reducer to output swing pinion for 360 degree rotation.

Swing brake

Spring set hydraulically released multiple disk brake mounted on swing motor.

Swing circle

Single row ball bearing with internal, integral swing gear.

Swing Lock 2 Position lock for transportation.

5. LOWER MACHINERY

5.1 Carbody

The durable carbody features steel welded construction with extendible axles.

5.2 Crawler

Crawler assemblies can be hydraulically extended for wide-track operation or retracted for transportation. Crawler belt tension adjusted with hydraulic jack and maintained by shims between the idler block and frame.

5.3 Crawler drive

The independent hydraulic propel drive is built into each crawler side frame. Each drive consists of a hydraulic motor driving a propel sprocket through a planetary gear box. The hydraulic motor and gearbox are built into the crawler side frame within the shoe width.

5.4 Crawler brakes

Spring set, hydraulically released, multiple disk-type parking brakes are built into each propel drive.

5.5 Steering mechanism

The hydraulic propel system provides both skid steering (driving one track only) and counter-rotating steering (driving each track in opposite direction).

5.6 Crawler shoes

63 shoes, 36" (914 mm) wide each crawler.

5.7 Track rollers

The track rollers are sealed for maintenance-free operation.

6. CRANE ATTACHMENTS

6.1 Crane boom

The welded lattice construction uses tubular, high-tension steel chords with pin connections between sections.

Maximum boom length	200' (61.0 m)
Basic boom length	40' (12.2 m)
Boom base section	19' (5.8 m)
Boom tip section	21' (6.4 m)

6.2 Boom insert (Optional)

An optional boom inserts is available to provide extension capabilities. It also has welded lattice construction with tubular, high-tension steel chords and pin connections.

Boom insert 10' (3.1 m), 20' (6.1 m), 40' (12.2 m)

6.3 Jib (Optional)

The optional jib employs welded lattice construction with tubular, high-tension steel chords with pin connections between sections.

Maximum jib length	60' (18.3 m)
Basic jib length	30' (9.1 m)
Jib base section	15' (4.6 m)

Jib tip section 15' (4.6 m)

Jib insert 10' (3.1 m), 20' (6.1 m)

Jib inserts are available to provide extension capabilities. They also have welded lattice construction with tubular, high-tension steel chords and pin connections.

Jib is extendible on booms of 80' (24.4 m) through 180' (54.9 m)

6.4 Auxiliary sheave (Optional)

Auxiliary sheave is extendible on booms of 40' (12.2 m) to 190' (57.9 m).

6.5 Boom hoist reeving

Twelve (12) parts of 5/8" (16.0 mm) dia. high strength wire rope.

6.6 Boom backstops

Telescopic type with spring bumper.

7. AUXILIARY EQUIPMENT

7.1 Lights

Tow (2) Front flood lights

One (1) Cab inside light

7.2 Gauges and warning display

Gauges

One (1) Tachometer

One (1) Hour meter

One (1) Fuel gauge

One (1) Water temperature gauge for engine

Warning display

Battery charge

Engine oil pressure

Air cleaner

Engine oil filter

Control main pressure

Hydraulic oil temperature

7.3 Others

Air conditioner

Drum turn indicator (front and rear drum)

Foot acceleration pedal

Electric fuel pump

Counterweight self-removal device

8. SAFETY SERVICE

Function lock lever

Boom over hoist limit switch

Signal horn

Front and rear hoist drum lock

Swing alarm (buzzer and lamps)

Over load preventive device (Load Moment Indicator)

Hook over hoist shut off (Anti-two-block)

Boom angle indicator
Boom hoist drum lock
Swing lock
Boom backstops

9. TOOLS AND ACCESSORIES

A set of tools and accessories are furnished.

10. OPTIONAL EQUIPMENT

Hydraulic tagline
Travel kit
Third drum
Pillow plate for boom self-erection
Custom color

All specifications are subject to change without notice.

Winch Performance Data

Line speed and line pull based on Hino J08E-TM at 2,000 rpm.

Line speed and line pull based on single line. Line pull is not based on wire rope strength.

1. Front and rear drum

		Line speed (ft/min)							
		Layer	1	2	3	4	5	6	7
Line Pull (lbs)	0	394	420	446	472	499	525	Storage only	
	5,000	394	420	446	472	499	525		
	10,000	353	353	353	353	353	353		
	15,000	235	235	235	235	235	235		
	17,000	208	208	208	208	208	208		
	20,000	177	177	177	177	179	182		
	25,000	141	146	148	149	149			
	32,000	115							
Storage Capacity (ft)		130	139	148	156	165	174	183	

Rated Line Pull = 17,000 lbs

Maximum Line Pull = 32,000 lbs

Total Storage Capacity = 1,095 ft

2. Third drum (Optional)

		Line speed (ft/min)							
		Layer	1	2	3	4	5	6	7
Line Pull (lbs)	0	394	420	446	472	499	525	Storage only	
	5,000	394	420	446	472	499	525		
	10,000	353	353	353	353	353	353		
	15,000	235	235	235	235	235	235		
	17,000	208	208	208	208	208	208		
	20,000	177	177	177	177	179	182		
	25,000	141	146	148	149	149			
	32,000	115							
Storage Capacity (ft)		130	139	148	156	165	174	183	

Rated Line Pull = 17,000 lbs

Maximum Line Pull = 32,000 lbs

Total Storage Capacity = 1,095 ft

Wire Rope Specifications

Use	Construction	No load diameter	Length	Safety Factor	Required minimum breaking strength
Front drum	6 x 25 Filler IWRC Right hand lay, Regular lay	0.887" to 0.904" (22.54 mm to 22.97 mm)	869' (265 m)	3.5: 1	59,500 lbs (26,990 kg)
Rear drum	6 x 25 Filler IWRC Right hand lay, Regular lay	0.887" to 0.904" (22.54 mm to 22.97 mm)	673' (205 m)	3.5: 1	59,500 lbs (26,990 kg)
Third drum (Optional)	6 x 25 Filler IWRC Right hand lay, Regular lay	0.887" to 0.904" (22.54 mm to 22.97 mm)	869' (265 m)	3.5: 1	59,500 lbs (26,990 kg)
Boom drum	6 x 31 Warrington seal Right hand lay, Regular lay	0.639" to 0.653" (16.24 mm to 16.58 mm)	492' (150 m)	3.5: 1	47,180 lbs (21,400 kg)

CK850-III General Dimensions

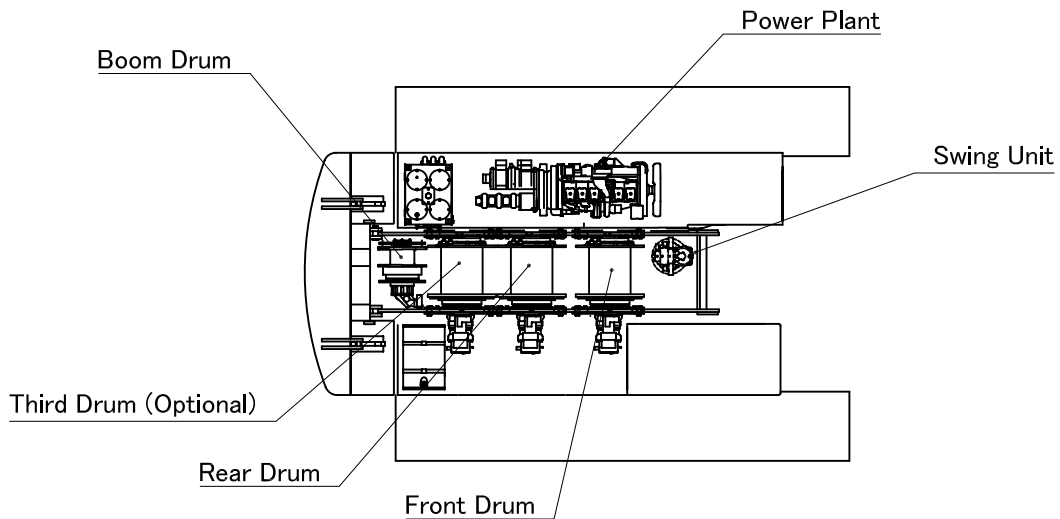
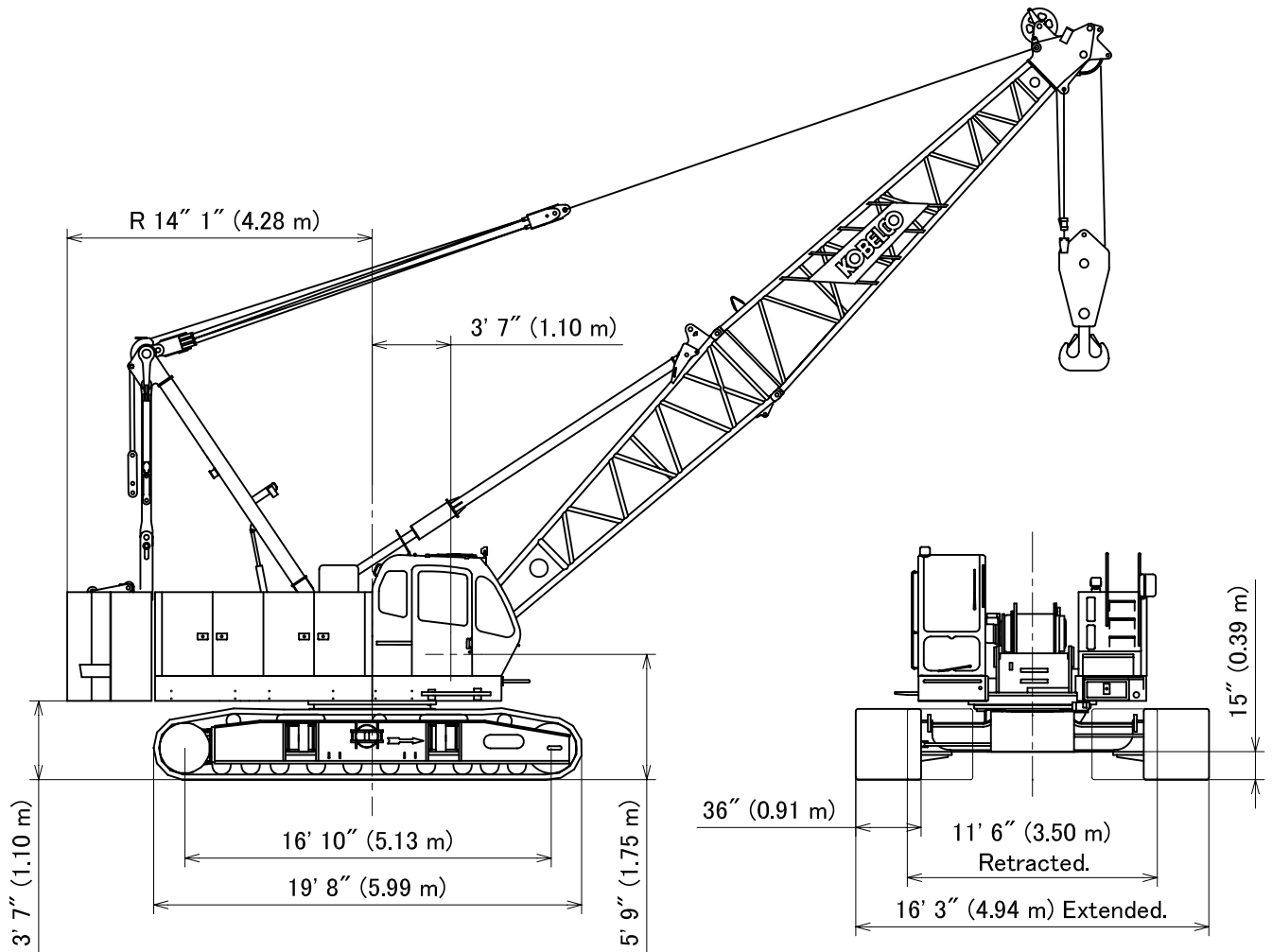

When installing optional third drum, add 4,260 lbs (1,930 kg)

Base Machine -1

Weight: 89,980 lbs (40,820 kg)

Boom base, Gantry, Crawler, Wire ropes (Front, Rear and Boom hoist drums)

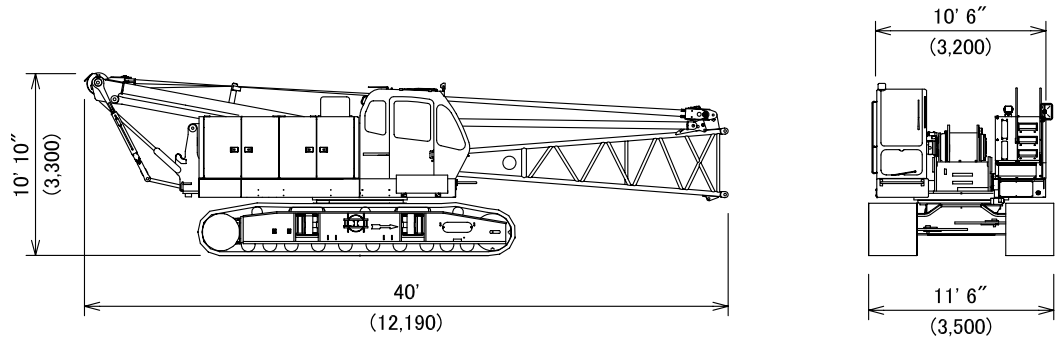

Base Machine -2

Weight: 85,350 lbs (38,700 kg)

Gantry, Crawler, Wire ropes (Front, Rear and Boom hoist drums)

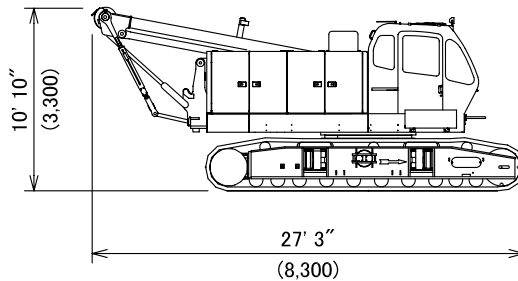

Base Machine -3

Weight: 52,500 lbs (23,800 kg)

Gantry, Wire ropes (Front, Rear and Boom hoist drums)

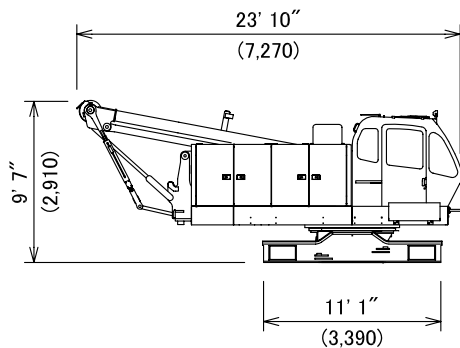

Crawler

Weight: 16,320 lbs (7,400 kg)

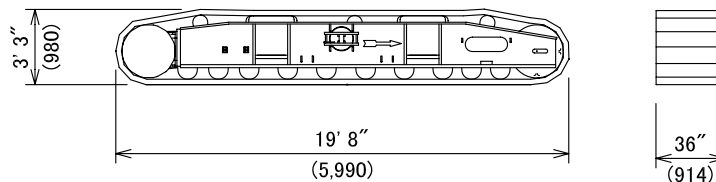

Counterweight (A)

Weight: 27,340 lbs (12,400 kg)

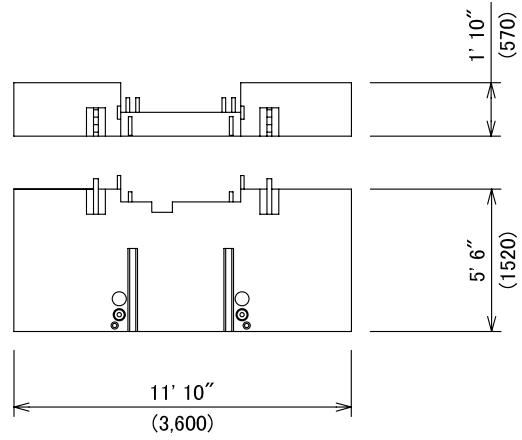

Counterweight (B)

Weight: 27,560 lbs (12,500 kg)

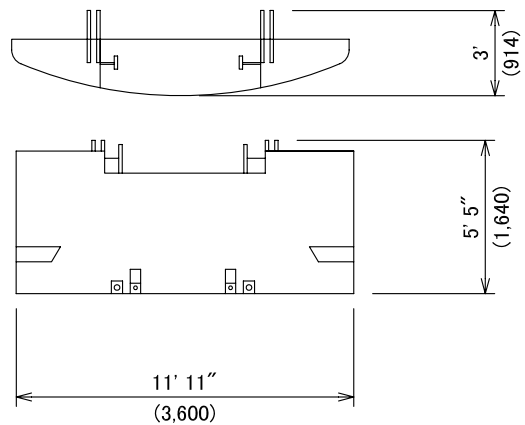

Carbody Weight

Weight: 7,360 lbs (3,340 kg)

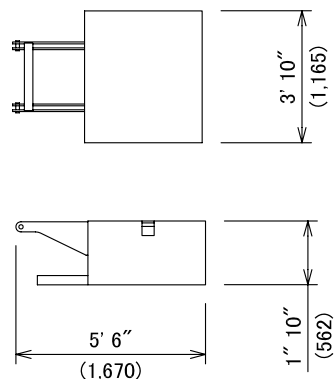

Boom Base

Weight: 2,230 lbs (1,010 kg)

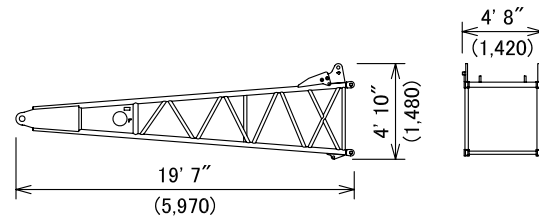

Boom Tip

Weight: 2,380 lbs (1,080 kg)
Includes cable roller and guy lines.

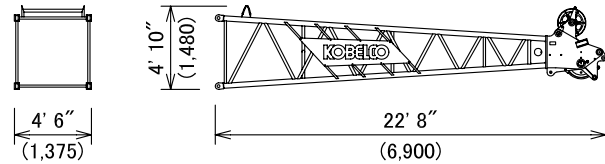

10 ft (3.0 m) Insert Boom

Weight: 750 lbs (340 kg)
Includes cable roller and guy lines.

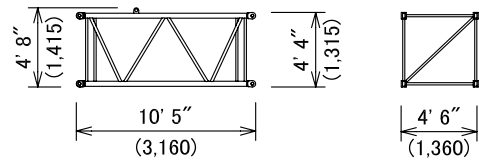

20 ft (6.1 m) Insert Boom

Weight: 1,230 lbs (560 kg)
Includes cable roller and guy lines.

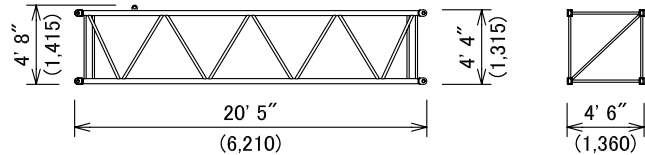

40 ft (12.2 m) Insert Boom

Weight: 2,190 lbs (990 kg)
Includes cable roller and guy lines.

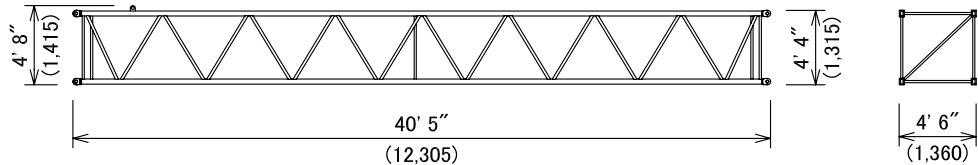

40 ft (12.2 m) Insert Boom (with lug)

Weight: 2,220 lbs (1,010 kg)
Includes cable roller and guy lines.

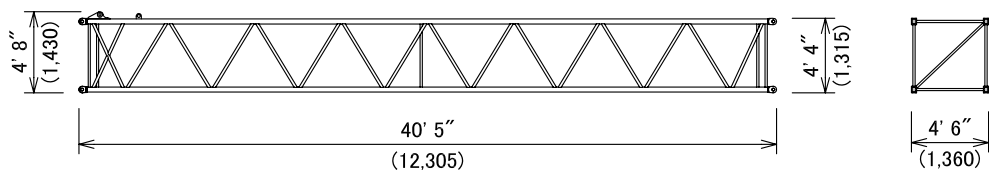

Auxiliary Sheave

Weight: 320 lbs (145 kg)

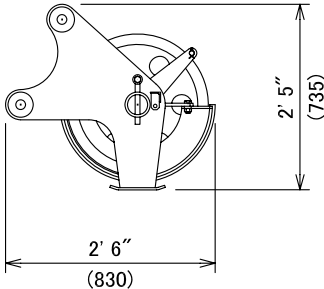

Jib Tip

Weight: 620 lbs (280 kg)
Includes cable roller.

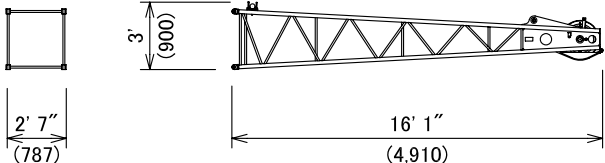

Jib Base and Strut

Weight: 1,210 lbs (550 kg)
Includes guy line.

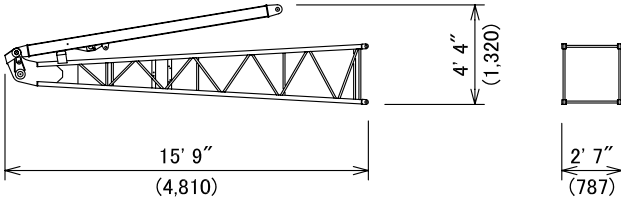

10 ft (3.0 m) Insert Jib

Weight: 290 lbs (130 kg)
Includes cable roller and guy line.

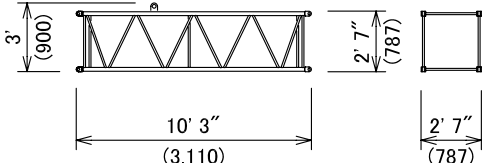

20 ft (6.1 m) Jib Insert

Weight: 490 lbs (220 kg)
Includes cable roller and guy line.

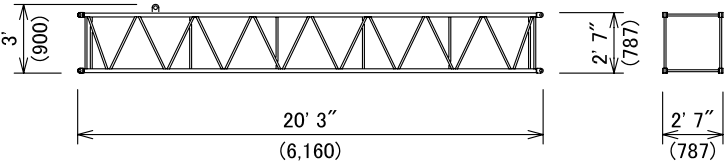

Shipping plan for 200 ft Boom and 60 ft Jib

Description of Item	Weight		Trailer Loads			
	lbs	(kg)	#1	#2	#3	#4
Base Machine with Boom Base and Crawlers*	89,980	(40,820)	1			
Counterweight (A)	27,340	(12,400)		1		
Counterweight (B)	27,560	(12,500)			1	
Carbody Weight	7,360	(3,340)		1	1	
10 ft Insert Boom and Guy Line	750	(340)		1	1	
20 ft Inset Boom and Guy Line	1,230	(560)				1
40 ft Insert Boom and Guy Line	2,190	(990)		1	1	
40 ft Insert Boom (w/ Lug) and Guy Line	2,220	(1,010)				1
Boom Tip and Guy Line	2,380	(1,080)				1
Jib Base and Guy Line	1,210	(550)		1		
10 ft Inset Jib and Guy Line	290	(130)		1		
20 ft Inset Jib and Guy Line	490	(220)		1		
Jib Tip	620	(280)		1		
Approx. Total Shipping Weight		lbs (kg)	89,980 (40,820)	40,250 (18,250)	37,860 (17,170)	5,830 (2,650)

* Third drum is not included.

Loads for transportation were targeted at 45,000 lbs, 8' 6" wide, 48' long and 13' 6" high from ground.

This may vary depending on truck/trailer weight, style of trailer and state low.

Trailer #1

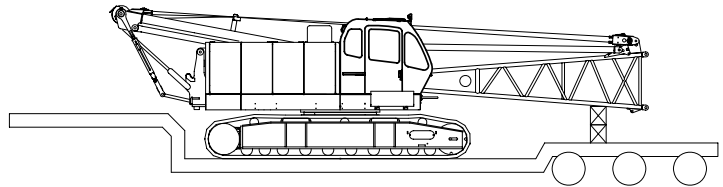

Trailer #2

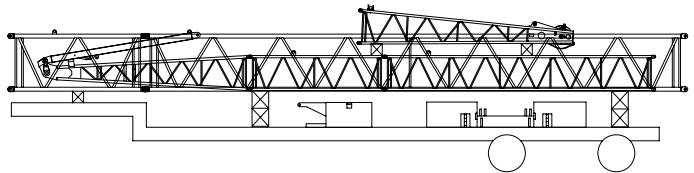

Trailer #3

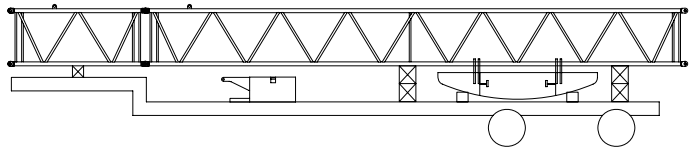

Trailer #4

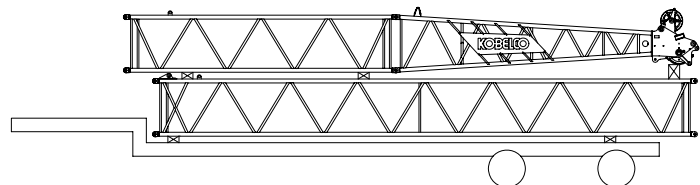

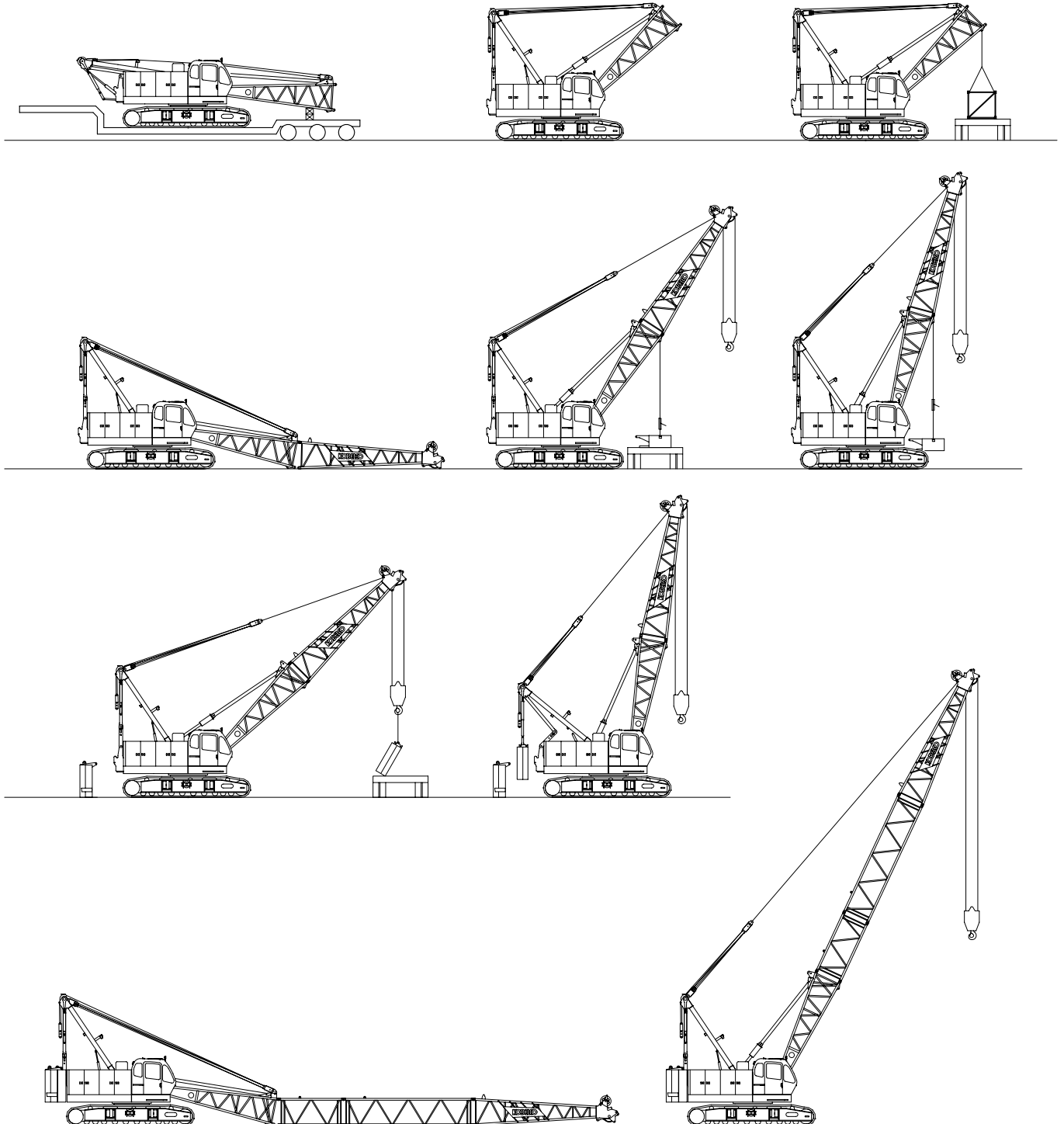

(Standard equipment)

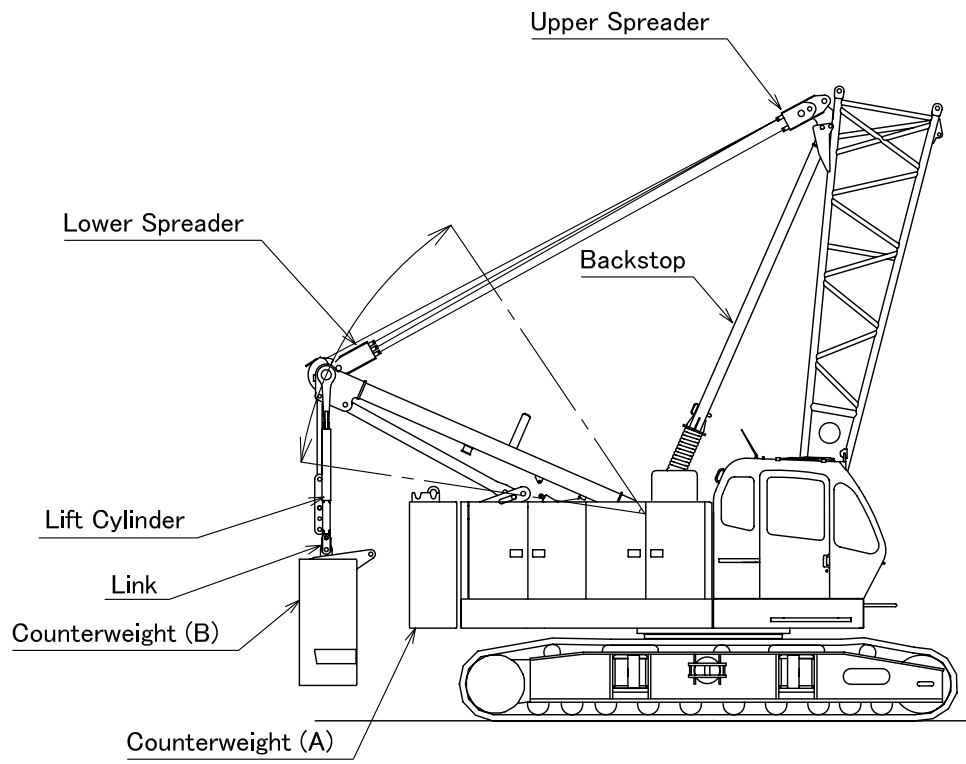

Boom Arrangement

Boom	Insert Boom				Aux Sheave	Fixed Jib
	10 ft	20 ft	40ft (40)	40 ft (40A)		
40 ft	-	-	-	-	Y1	
50 ft	1	-	-	-	Y1	
60 ft	2	-	-	-	Y1	
70 ft	1	1	-	-	Y1	
80 ft	2	1	-	-	Y1	Y2
	-	-	-	1	Y1	
90 ft	1	2	-	-	Y1	Y2
	1	-	-	1	Y1	
100 ft	2	2	-	-	Y1	
	2	-	-	1	Y1	Y2
110 ft	1	1	-	1	Y1	Y2
120 ft	2	1	-	1	Y1	Y2
130 ft	1	2	-	1	Y1	Y2
140 ft	2	2	-	1	Y1	Y2
150 ft	1	1	1	1	Y1	Y2
160 ft	2	1	1	1	Y1	Y2
170 ft	1	2	1	1	Y1	Y2
180 ft	2	2	1	1	Y1	Y2
190 ft	1	1	2	1	Y1	
200 ft	2	1	2	1		

Jib Arrangement

Jib	Insert Jib	
	10 ft	20 ft
30 ft	-	-
40 ft	1	-
50 ft	-	1
60 ft	1	1

Y1: Auxiliary sheave can be attached.
 Y2: Fixed jib can be attached.
 To install fixed jib, one 40A (40 ft insert boom with lug) is required.

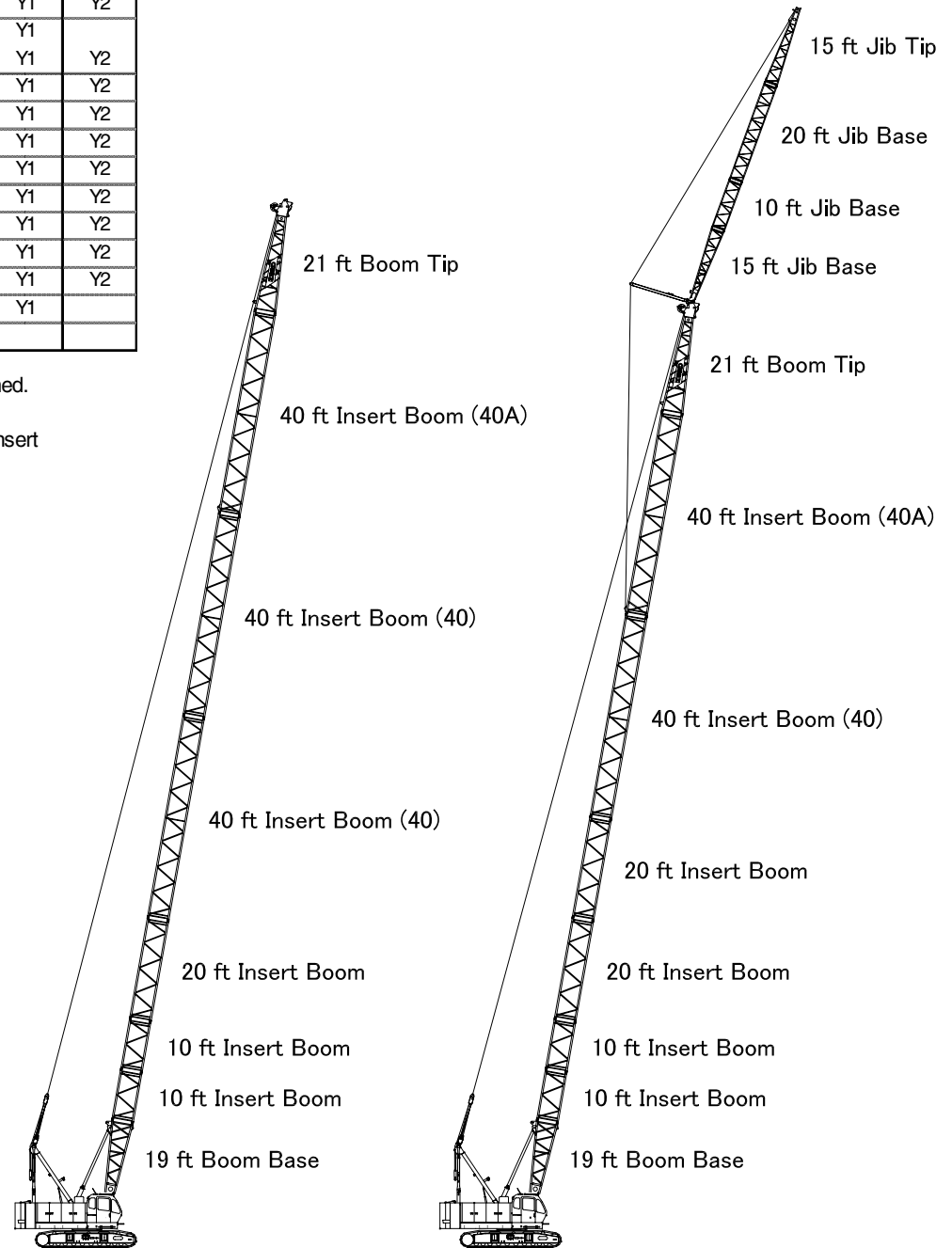

200 ft (61.0 m) Main Boom

180 ft (54.9 m) Main Boom and 60 ft (18.3 m) Fixed Jib

CK850-III Main Boom Working Range

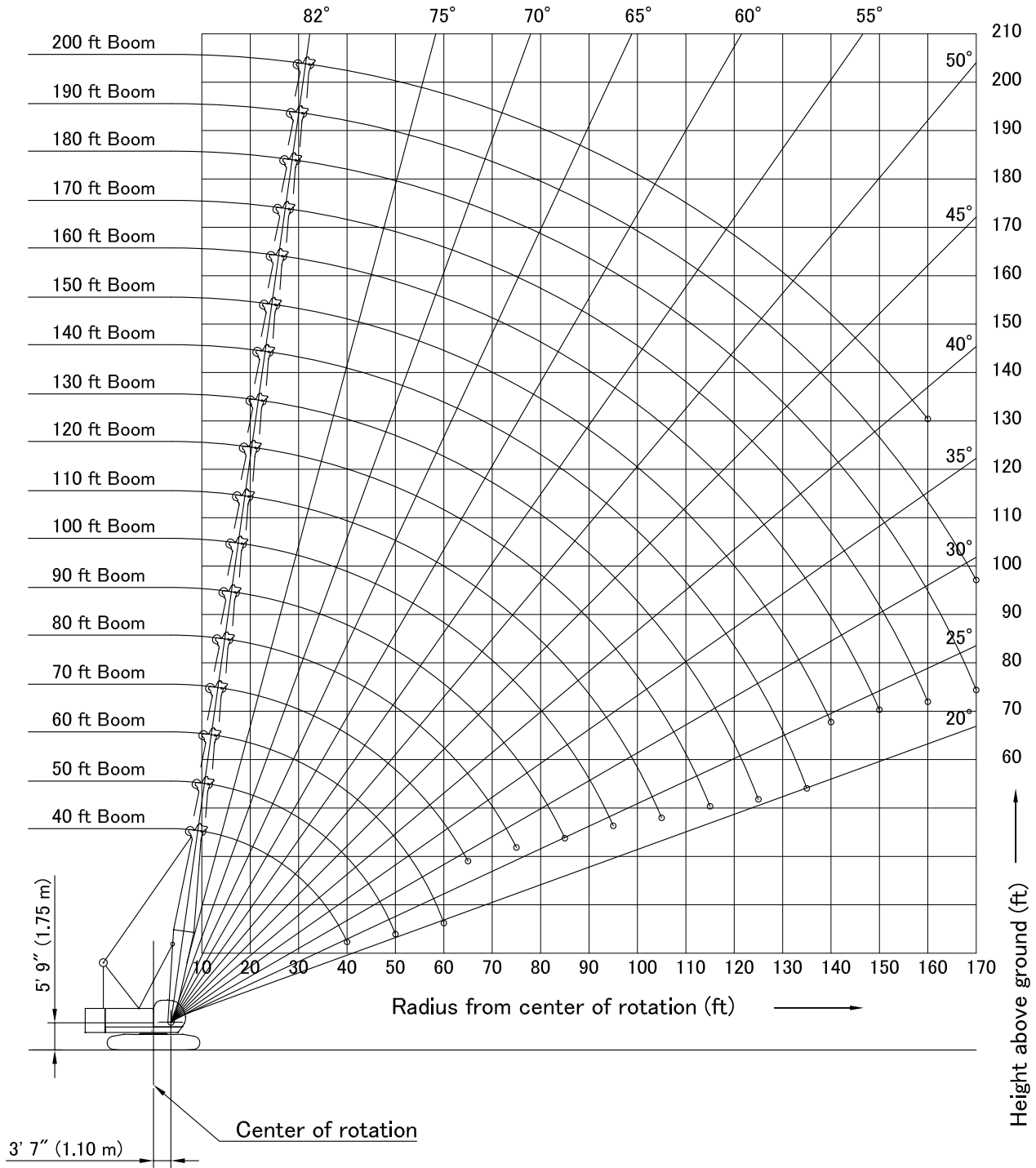

CK850-III Jib Working Range



Jib Offset 10°

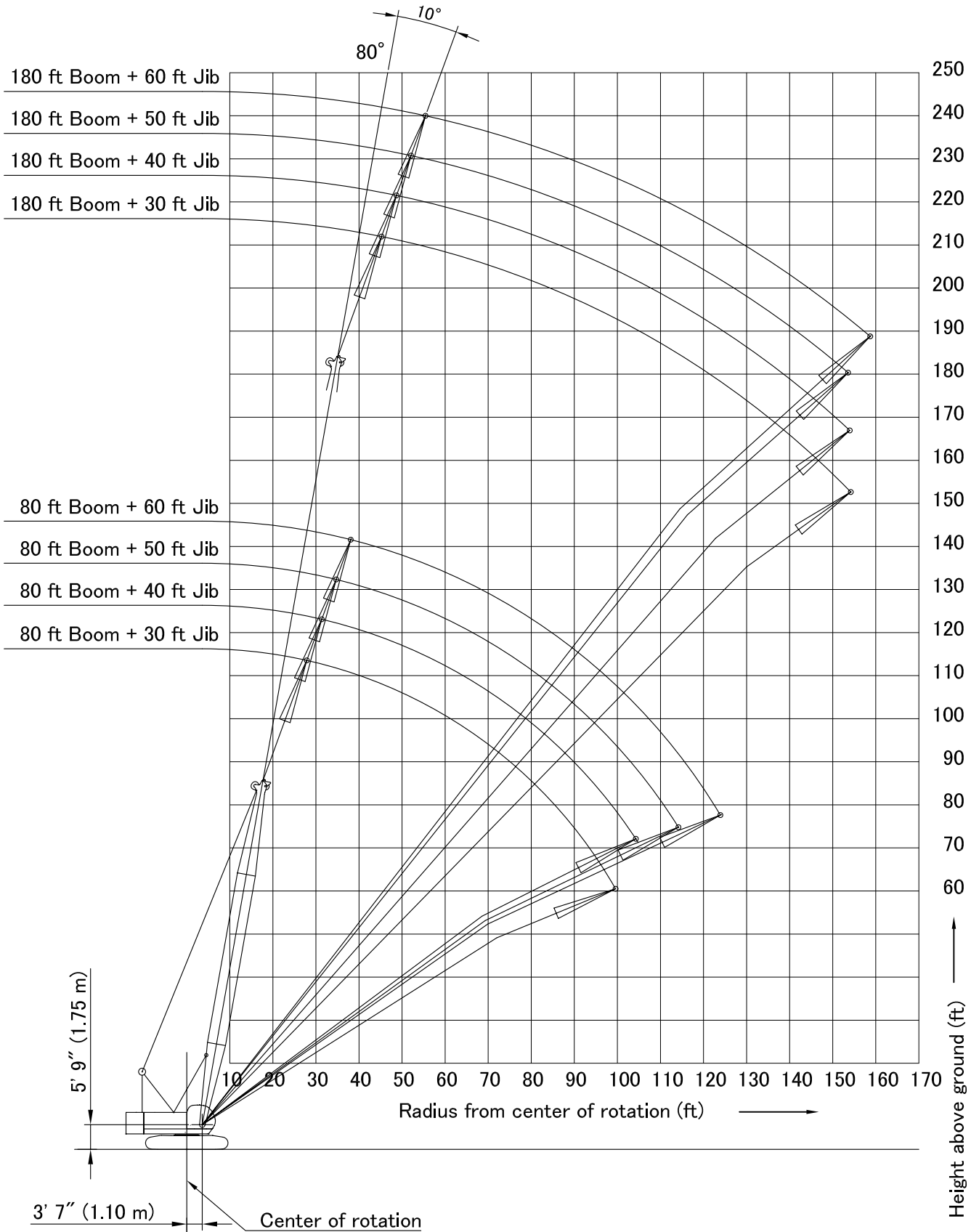

CK850-III Jib Working Range



Jib Offset 30°

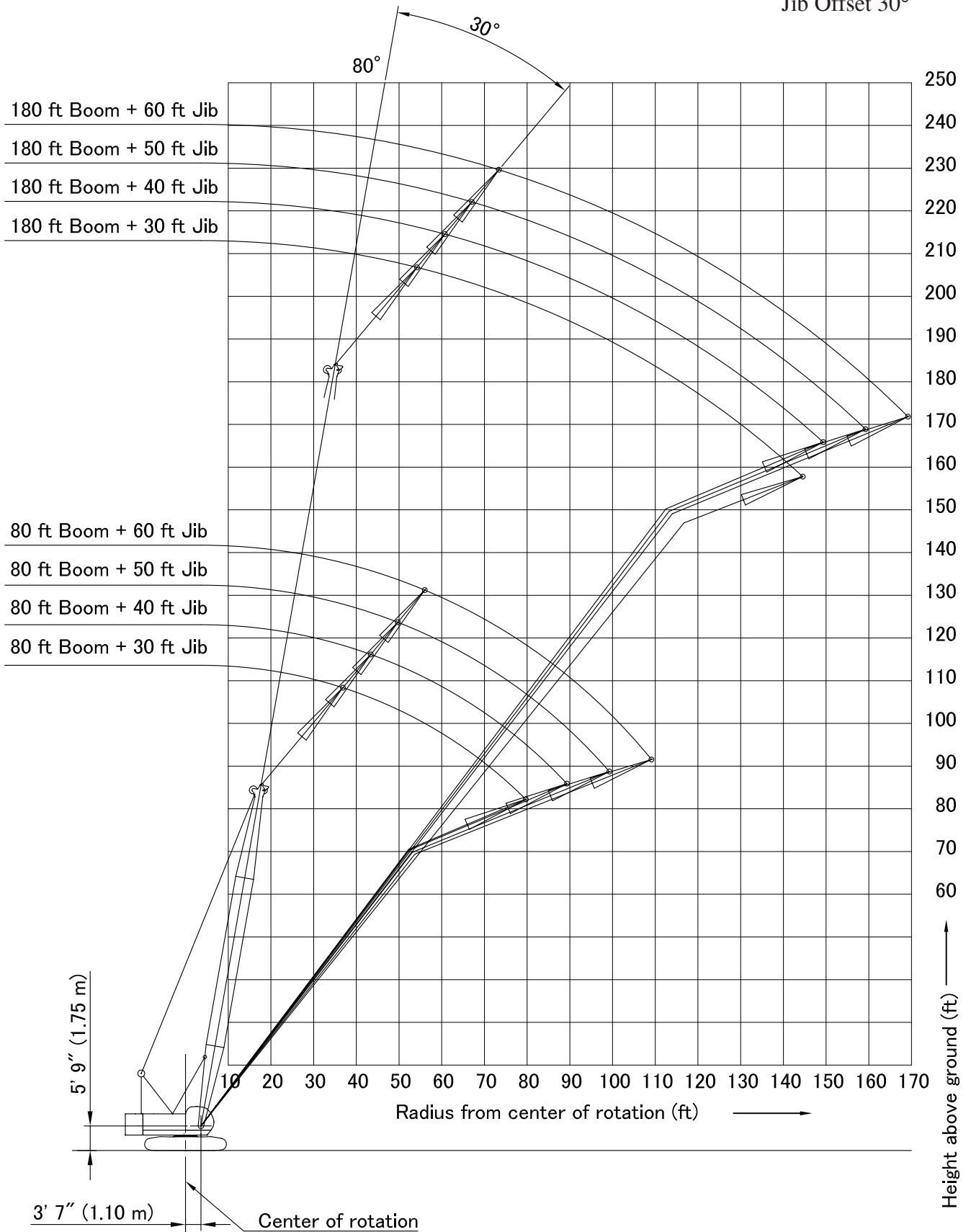

KOBELCO CK850-III Main Boom Rated Loads in Pounds

Counterweight: 54,900 lbs (24,900 kg)

Carbody weight: 14,720 lbs (6,680 kg)

Supplemental Data

1. Rated loads included in the charts are the maximum allowable freely suspended loads at a given boom length, boom angle and load radius, and have been determined for the machine standing level on firm supporting surface under ideal operating conditions. The user must limit or de-rate rated loads to allow for adverse conditions (such as soft or uneven ground, out-of-level conditions, wind, side loads, pendulum action, jerking or sudden stopping of loads, inexperience of personnel, multiple machine lifts, and traveling with a load).
2. Rated loads do not exceed 75% of minimum tipping loads. Rated loads based on factors other than machine stability such as structural competence are shown by asterisk * in the charts.
3. The machine must be reeved and set-up as stated in the operation manual and all the instruction manuals if these manuals are missing, obtain replacements.
 - 1) The crane must be leveled to within 1% on a firm supporting surface.
 - 2) Boom backstops are required for all boom lengths.
 - 3) Gantry must be fully raised position for all operations.
 - 4) Crawlers must be fully extended and be locked in position.
 - 5) Counterweight: 54,900 lbs.
 - 6) Carbody weight: 14,720 lbs
4. Do not attempt to lift where no radius on load is listed as crane may tip or collapse.
5. Attempting to lift more than rated loads may cause machine to tip or collapse. Do not tip machine to determine rated loads.
6. Weight of hooks, hook blocks, slings and other lifting devices are a part of the total load. Their total weight must be subtracted from the rated load to obtain the weight that can be lifted.
7. When lifting over boom point with jib or auxiliary sheave, rated loads for the boom must be deducted as shown below.

Jib Length	Aux. Sheave	30 ft	40 ft	50 ft	60 ft
Deduct (lbs)	320	2,400	3,200	4,200	5,200

8. The total load that can be lifted by the jib is limited by rated jib loads.

9. Boom lengths for jib mounting are 80 ft (24.4 m) to 180 ft (54.9 m).
10. The total load that can be lifted by the auxiliary sheave is: the rated load for the boom (without auxiliary sheave installed) minus 320 lbs; however, the auxiliary sheave rated load should not exceed 17,000 lbs.
11. Permissible boom lengths for installing auxiliary sheave are from 40 ft (12.2 m) to 190 ft (57.9 m).
12. The boom should be erected over the front of the crawlers, not laterally.
13. Least stable position is over the side.
14. Maximum hoist load for number of reeving parts of line for hoist rope.

Maximum Load for Main Boom

No. of Parts Line	1	2	3	4	5
Maximum Loads (lbs)	17,000	34,000	51,000	68,000	85,000

No. of Parts Line	6	7	8	9	10
Maximum Loads (lbs)	102,000	119,000	136,000	153,000	170,000

Maximum Load for Fixed Jib

No. of Parts Line	1	2
Maximum Loads (lbs)	17,000	24,000

Maximum Load for Auxiliary Sheave

No. of Parts Line	1
Maximum Loads (lbs)	17,000

15. Rated loads listed apply only to the machine as originally manufactured and designed by KOBELCO CRANES CO.,LTD. Modifications to this machine or use of equipment other than that specified can reduce operating capacity.
16. Designed and rated to comply ANSI code B30.5.

Operation of this equipment in excess of rated loads or disregard of instruction void the warranty

CK850-III Main Boom Rated Loads in Pounds

2 Counterweights + 2 Low Weights - Crawlers fully extended

40' Boom			50' Boom			60' Boom		
Load Radius (ft)	Boom Angle (deg.)	360° Rated Load (lbs)	Load Radius (ft)	Boom Angle (deg.)	360° Rated Load (lbs)	Load Radius (ft)	Boom Angle (deg.)	360° Rated Load (lbs)
10.0	81.7	170,000 *	12.0	81.1	166,400 *	13.0	81.6	154,200 *
11.0	80.3	170,000 *	13.0	79.9	154,400 *	14.0	80.7	143,800 *
12.0	78.8	166,600 *	14.0	78.8	144,000 *	15.0	79.7	134,700 *
13.0	77.4	154,600 *	15.0	77.6	134,900 *	16.0	78.7	126,700 *
14.0	75.9	144,200 *	16.0	76.4	126,900 *	17.0	77.7	119,500 *
15.0	74.4	135,100 *	17.0	75.2	119,700 *	18.0	76.8	113,000 *
16.0	72.9	127,100 *	18.0	74.0	113,200 *	19.0	75.8	105,460
17.0	71.4	119,900 *	19.0	72.8	105,660	20.0	74.8	97,130
18.0	69.9	113,400 *	20.0	71.6	97,350	22.0	72.8	83,790
19.0	68.3	105,820	22.0	69.2	84,010	24.0	70.8	73,560
20.0	66.7	97,500	24.0	66.7	73,810	26.0	68.7	65,490
22.0	63.6	84,190	26.0	64.2	65,760	28.0	66.6	58,970
24.0	60.3	74,000	28.0	61.6	59,230	30.0	64.5	53,570
26.0	56.9	65,980	30.0	58.9	53,850	32.0	62.4	49,030
28.0	53.4	59,480	32.0	56.2	49,310	34.0	60.2	45,170
30.0	49.7	54,100	34.0	53.3	45,480	36.0	58.0	41,840
32.0	45.7	49,580	36.0	50.4	42,150	38.0	55.7	38,950
34.0	41.5	45,740	38.0	47.3	39,280	40.0	53.3	36,410
36.0	36.9	42,460	40.0	44.1	36,750	45.0	47.0	31,230
38.0	31.6	39,590	45.0	34.9	31,590	50.0	40.0	27,290
40.0	25.5	34,830 *	50.0	22.7	26,890 *	55.0	31.7	24,200
						60.0	20.6	21,600 *
70' Boom			80' Boom			90' Boom		
Load Radius (ft)	Boom Angle (deg.)	360° Rated Load (lbs)	Load Radius (ft)	Boom Angle (deg.)	360° Rated Load (lbs)	Load Radius (ft)	Boom Angle (deg.)	360° Rated Load (lbs)
14.0	82.0	143,600 *	16.0	81.6	126,300 *	17.0	81.9	118,820 *
15.0	81.2	134,500 *	17.0	80.8	119,100 *	18.0	81.2	112,400 *
16.0	80.3	126,500 *	18.0	80.1	112,600 *	19.0	80.6	105,220
17.0	79.5	119,300 *	19.0	79.4	105,290	20.0	79.9	96,870
18.0	78.7	112,800 *	20.0	78.6	96,930	22.0	78.6	83,480
19.0	77.8	105,400	22.0	77.2	83,550	24.0	77.3	73,230
20.0	77.0	97,060	24.0	75.7	73,320	26.0	76.0	65,140
22.0	75.3	83,700	26.0	74.2	65,230	28.0	74.7	58,570
24.0	73.6	73,470	28.0	72.7	58,680	30.0	73.4	53,150
26.0	71.9	65,380	30.0	71.2	53,260	32.0	72.0	48,580
28.0	70.1	58,840	32.0	69.7	48,690	34.0	70.7	44,700
30.0	68.4	53,430	34.0	68.1	44,840	36.0	69.3	41,380
32.0	66.6	48,890	36.0	66.6	41,490	38.0	68.0	38,440
34.0	64.8	45,030	38.0	65.0	38,580	40.0	66.6	35,890
36.0	63.0	41,680	40.0	63.4	36,020	45.0	63.0	30,660
38.0	61.1	38,800	45.0	59.3	30,820	50.0	59.4	26,670
40.0	59.2	36,240	50.0	55.0	26,820	55.0	55.6	23,520
45.0	54.3	31,040	55.0	50.5	23,670	60.0	51.6	20,960
50.0	49.0	27,070	60.0	45.6	21,140	65.0	47.4	18,870
55.0	43.3	23,960	65.0	40.3	19,060	70.0	42.9	17,100
60.0	36.9	21,450	70.0	34.4	17,350	75.0	37.9	15,630
65.0	29.3	19,420	75.0	27.3	15,890	80.0	32.3	14,370
						85.0	25.7	13,310

CK850-III Main Boom Rated Loads in Pounds

2 Counterweights + 2 Low Weights - Crawlers fully extended

100' Boom			110' Boom			120' Boom		
Load Radius (ft)	Boom Angle (deg.)	360° Rated Load (lbs)	Load Radius (ft)	Boom Angle (deg.)	360° Rated Load (lbs)	Load Radius (ft)	Boom Angle (deg.)	360° Rated Load (lbs)
19.0	81.5	101,850 *	20.0	81.8	92,590 *	22.0	81.5	80,680 *
20.0	80.9	96,800	22.0	80.7	83,260	24.0	80.5	72,950
22.0	79.8	83,400	24.0	79.7	73,010	26.0	79.6	64,810
24.0	78.6	73,120	26.0	78.6	64,900	28.0	78.6	58,240
26.0	77.4	65,010	28.0	77.5	58,330	30.0	77.6	52,800
28.0	76.3	58,440	30.0	76.5	52,880	32.0	76.6	48,230
30.0	75.1	53,020	32.0	75.4	48,320	34.0	75.6	44,330
32.0	73.9	48,450	34.0	74.3	44,440	36.0	74.7	40,980
34.0	72.7	44,550	36.0	73.2	41,090	38.0	73.7	38,050
36.0	71.5	41,200	38.0	72.1	38,160	40.0	72.7	35,470
38.0	70.3	38,290	40.0	71.0	35,600	45.0	70.1	30,220
40.0	69.0	35,730	45.0	68.2	30,350	50.0	67.6	26,210
45.0	65.9	30,480	50.0	65.4	26,340	55.0	65.0	23,010
50.0	62.7	26,470	55.0	62.5	23,170	60.0	62.3	20,450
55.0	59.5	23,320	60.0	59.5	20,610	65.0	59.5	18,320
60.0	56.1	20,740	65.0	56.4	18,490	70.0	56.7	16,530
65.0	52.5	18,620	70.0	53.2	16,710	75.0	53.8	15,010
70.0	48.8	16,860	75.0	49.9	15,210	80.0	50.8	13,710
75.0	44.8	15,360	80.0	46.4	13,910	85.0	47.6	12,580
80.0	40.6	14,080	85.0	42.6	12,800	90.0	44.3	11,590
85.0	35.9	12,980	90.0	38.6	11,830	95.0	40.7	10,730
90.0	30.6	12,010	95.0	34.2	10,970	100.0	36.9	9,960
95.0	24.3	11,190	100.0	29.2	10,250	105.0	32.7	9,280
			105.0	23.2	9,610	110.0	27.9	8,680
						115.0	22.2	8,170
130' Boom			140' Boom			150' Boom		
Load Radius (ft)	Boom Angle (deg.)	360° Rated Load (lbs)	Load Radius (ft)	Boom Angle (deg.)	360° Rated Load (lbs)	Load Radius (ft)	Boom Angle (deg.)	360° Rated Load (lbs)
24.0	81.3	71,200 *	24.0	81.9	61,720 *	26.0	81.7	52,680 *
26.0	80.4	64,610	26.0	81.1	60,840 *	28.0	80.9	51,800 *
28.0	79.5	58,020	28.0	80.2	57,980	30.0	80.1	51,140 *
30.0	78.6	52,570	30.0	79.4	52,530	32.0	79.3	47,810
32.0	77.7	48,010	32.0	78.6	47,950	34.0	78.6	43,890
34.0	76.8	44,110	34.0	77.7	44,040	36.0	77.8	40,540
36.0	75.9	40,760	36.0	76.9	40,670	38.0	77.0	37,610
38.0	74.9	37,830	38.0	76.0	37,740	40.0	76.2	35,030
40.0	74.0	35,250	40.0	75.2	35,160	45.0	74.2	29,760
45.0	71.7	30,000	45.0	73.1	29,910	50.0	72.2	25,720
50.0	69.4	25,970	50.0	70.9	25,880	55.0	70.2	22,530
55.0	67.0	22,790	55.0	68.7	22,680	60.0	68.2	19,950
60.0	64.6	20,210	60.0	66.5	20,100	65.0	66.1	17,810
65.0	62.1	18,070	65.0	64.3	17,960	70.0	64.0	16,000
70.0	59.6	16,290	70.0	62.0	16,150	75.0	61.8	14,480
75.0	57.0	14,770	75.0	59.6	14,630	80.0	59.6	13,160
80.0	54.3	13,470	80.0	57.2	13,310	85.0	57.4	12,010
85.0	51.5	12,320	85.0	54.7	12,160	90.0	55.1	11,000
90.0	48.6	11,330	90.0	52.2	11,170	95.0	52.7	10,110
95.0	45.6	10,440	95.0	49.5	10,290	100.0	50.3	9,320
100.0	42.4	9,670	100.0	46.8	9,500	105.0	47.7	8,640
105.0	39.0	8,990	105.0	43.9	8,790	110.0	45.1	8,000
110.0	35.4	8,390	110.0	40.8	8,170	115.0	42.3	7,420
115.0	31.3	7,840	115.0	37.5	7,620	120.0	39.4	6,920
120.0	26.7	7,360	120.0	34.0	7,120	125.0	36.2	6,450
125.0	21.2	6,940	125.0	30.1	6,650	130.0	32.8	6,040
			130.0	25.7	6,260	135.0	29.1	5,660
			135.0	20.5	5,900	140.0	24.8	5,330

CK850-III Main Boom Rated Loads in Pounds

2 Counterweights + 2 Low Weights - Crawlers fully extended

160' Boom			170' Boom			180' Boom		
Load Radius (ft)	Boom Angle (deg.)	360° Rated Load (lbs)	Load Radius (ft)	Boom Angle (deg.)	360° Rated Load (lbs)	Load Radius (ft)	Boom Angle (deg.)	360° Rated Load (lbs)
28.0	81.5	44,090 *	28.0	82.0	38,800 *	30.0	81.8	33,730 *
30.0	80.7	43,430 *	30.0	81.3	38,130 *	32.0	81.1	33,060 *
32.0	80.0	42,760 *	32.0	80.6	37,470 *	34.0	80.5	32,620 *
34.0	79.3	42,100 *	34.0	79.9	37,030 *	36.0	79.8	31,960 *
36.0	78.6	40,520	36.0	79.2	36,370 *	38.0	79.2	31,520 *
38.0	77.8	37,560	38.0	78.6	35,710 *	40.0	78.5	31,080 *
40.0	77.1	34,980	40.0	77.9	34,780	45.0	76.9	29,250
45.0	75.2	29,710	45.0	76.1	29,510	50.0	75.3	25,220
50.0	73.4	25,680	50.0	74.4	25,460	55.0	73.6	22,000
55.0	71.5	22,480	55.0	72.6	22,260	60.0	72.0	19,400
60.0	69.6	19,880	60.0	70.9	19,660	65.0	70.3	17,260
65.0	67.7	17,720	65.0	69.1	17,520	70.0	68.6	15,450
70.0	65.7	15,930	70.0	67.2	15,710	75.0	66.8	13,910
75.0	63.7	14,390	75.0	65.4	14,170	80.0	65.1	12,560
80.0	61.7	13,070	80.0	63.5	12,850	85.0	63.3	11,410
85.0	59.7	11,920	85.0	61.6	11,680	90.0	61.5	10,400
90.0	57.6	10,910	90.0	59.7	10,670	95.0	59.7	9,500
95.0	55.4	10,000	95.0	57.7	9,780	100.0	57.8	8,700
100.0	53.2	9,210	100.0	55.7	8,990	105.0	55.9	8,000
105.0	50.9	8,500	105.0	53.6	8,260	110.0	54.0	7,340
110.0	48.6	7,870	110.0	51.5	7,620	115.0	52.0	6,760
115.0	46.1	7,290	115.0	49.3	7,050	120.0	49.9	6,230
120.0	43.6	6,760	120.0	47.0	6,520	125.0	47.8	5,700
125.0	40.9	6,280	125.0	44.7	6,040	130.0	45.6	5,220
130.0	38.1	5,860	130.0	42.2	5,570	135.0	43.3	4,780
135.0	35.0	5,440	135.0	39.6	5,150	140.0	40.9	4,380
140.0	31.8	5,070	140.0	36.9	4,760	145.0	38.4	4,030
145.0	28.1	4,710	145.0	34.0	4,380	150.0	35.8	3,680
150.0	24.0	4,380	150.0	30.8	4,050	155.0	33.0	3,370
			155.0	27.3	3,760	160.0	29.9	3,100
			160.0	23.3	3,500	165.0	26.5	2,840
						170.0	22.6	2,620

190' Boom			190' Boom			200' Boom		
Load Radius (ft)	Boom Angle (deg.)	360° Rated Load (lbs)	Load Radius (ft)	Boom Angle (deg.)	360° Rated Load (lbs)	Load Radius (ft)	Boom Angle (deg.)	360° Rated Load (lbs)
32.0	81.6	29,540 *	160.0	34.8	3,040	34.0	81.4	25,790 *
34.0	81.0	28,880 *	165.0	32.0	2,770	36.0	80.9	25,350 *
36.0	80.4	28,430 *	170.0	29.1	2,510	38.0	80.3	24,910 *
38.0	79.8	27,990 *				40.0	79.7	24,470 *
40.0	79.2	27,550 *				45.0	78.2	23,360 *
45.0	77.6	26,450 *				50.0	76.8	22,480 *
50.0	76.1	25,300				55.0	75.3	21,380 *
55.0	74.5	22,110				60.0	73.8	19,310
60.0	72.9	19,510				65.0	72.3	17,150
65.0	71.3	17,350				70.0	70.8	15,320
70.0	69.7	15,540				75.0	69.3	13,770
75.0	68.1	13,990				80.0	67.7	12,430
80.0	66.5	12,650				85.0	66.2	11,260
85.0	64.8	11,500				90.0	64.6	10,250
90.0	63.2	10,470				95.0	63.0	9,340
95.0	61.4	9,560				100.0	61.4	8,530
100.0	59.7	8,770				105.0	59.7	7,820
105.0	57.9	8,040				110.0	58.1	7,160
110.0	56.1	7,400				115.0	56.3	6,560
115.0	54.3	6,810				120.0	54.6	5,970
120.0	52.4	6,280				125.0	52.8	5,440
125.0	50.5	5,750				130.0	51.0	4,960
130.0	48.5	5,260				135.0	49.1	4,510
135.0	46.4	4,800				140.0	47.2	4,100
140.0	44.3	4,400				145.0	45.2	3,700
145.0	42.1	4,010				150.0	43.1	3,350
150.0	39.8	3,680				155.0	41.0	3,040
155.0	37.4	3,350				160.0	38.7	2,730

CK850-III Jib Rated Loads in Pounds

2 Counterweights + 2 Low Weights - Crawlers fully extended

80' Boom									80' Boom								
Load Radius (ft.)	30' Jib				40' Jib				Load Radius (ft.)	50' Jib				60' Jib			
	10° Offset		30° Offset		10° Offset		30° Offset			10° Offset		30° Offset		10° Offset		30° Offset	
	Boom Angle (deg.)	Rated Load (lbs.)	Boom Angle (deg.)	Rated Load (lbs.)	Boom Angle (deg.)	Rated Load (lbs.)	Boom Angle (deg.)	Rated Load (lbs.)		Boom Angle (deg.)	Rated Load (lbs.)	Boom Angle (deg.)	Rated Load (lbs.)	Boom Angle (deg.)	Rated Load (lbs.)	Boom Angle (deg.)	Rated Load (lbs.)
30	79.3	24,000 *							38	79.3	20,000 *						
32	78.0	24,000 *							40	78.4	20,000 *			79.8	18,000 *		
34	77.0	24,000 *			79.3	24,000 *			45	76.1	20,000 *			77.7	17,940 *		
36	75.9	24,000 *			78.3	24,000 *			50	73.8	18,540 *			75.6	16,330 *		
38	74.9	24,000 *	79.6	20,230 *	77.4	24,000 *			55	71.3	16,950 *	78.0	11,080 *	73.3	14,900 *		
40	73.8	24,000 *	78.5	19,730 *	76.4	24,000 *			60	68.9	15,690 *	75.5	10,490 *	71.2	13,750 *	78.7	8,950 *
45	71.1	24,000 *	75.7	18,600 *	73.9	24,000 *	79.7	15,360 *	65	66.5	14,610 *	73.0	9,980 *	69.0	12,780 *	76.4	8,480 *
50	68.3	24,000 *	72.8	17,610 *	71.4	22,150 *	77.1	14,480 *	70	64.0	13,660 *	70.4	9,540 *	66.7	11,900 *	74.1	8,060 *
55	65.3	23,890	69.7	16,710 *	68.7	20,280 *	74.3	13,640 *	75	61.3	12,760 *	67.6	9,100 *	64.2	11,110 *	71.5	7,670 *
60	62.3	21,340	66.7	15,960 *	66.1	18,800 *	71.6	12,980 *	80	58.7	12,030 *	64.8	8,730 *	61.9	10,440 *	69.0	7,340 *
65	59.3	19,200	63.6	15,290 *	63.4	17,520 *	68.8	12,360 *	85	56.0	11,390 *	62.0	8,420 *	59.5	9,850 *	66.5	7,030 *
70	56.2	17,410	60.3	14,700 *	60.6	16,400 *	65.9	11,830 *	90	53.2	10,800 *	59.0	8,130 *	57.0	9,320 *	63.9	6,760 *
75	52.8	15,780	56.7	14,150 *	57.6	15,360 *	62.7	11,350 *	95	50.0	10,250 *	55.6	7,840 *	54.2	8,810 *	60.9	6,500 *
80	49.3	14,460	53.1	13,710 *	54.6	14,520 *	59.6	10,930 *	100	46.9	9,780 *	52.3	7,620 *	51.5	8,390 *	58.1	6,280 *
85	45.7	13,330			51.5	13,470	56.3	10,560 *	105	43.6	9,360 *			48.7	8,020 *	55.0	6,100 *
90	41.8	12,320			48.3	12,450	52.9	10,250 *	110	40.0	8,990 *			45.7	7,670 *	51.8	5,930 *
95	37.2	11,370			44.6	11,500			115	35.8	8,640 *			42.3	7,340 *		
100	32.4	10,600			40.8	10,710			120					38.8	7,050 *		
105					36.7	10,000			125					35.1	6,810 *		

90' Boom									90' Boom								
Load Radius (ft.)	30' Jib				40' Jib				Load Radius (ft.)	50' Jib				60' Jib			
	10° Offset		30° Offset		10° Offset		30° Offset			10° Offset		30° Offset		10° Offset		30° Offset	
	Boom Angle (deg.)	Rated Load (lbs.)	Boom Angle (deg.)	Rated Load (lbs.)	Boom Angle (deg.)	Rated Load (lbs.)	Boom Angle (deg.)	Rated Load (lbs.)		Boom Angle (deg.)	Rated Load (lbs.)	Boom Angle (deg.)	Rated Load (lbs.)	Boom Angle (deg.)	Rated Load (lbs.)	Boom Angle (deg.)	Rated Load (lbs.)
32	79.1	24,000 *							38	80.0	20,000 *						
34	78.1	24,000 *							40	79.2	20,030 *						
36	77.1	24,000 *			79.3	24,000 *			45	77.1	20,030 *			78.6	18,000 *		
38	76.2	24,000 *			78.4	24,000 *			50	75.0	19,400 *			76.6	17,040 *		
40	75.2	24,000 *	79.5	20,170 *	77.5	24,000 *			55	72.7	17,790 *	78.9	11,300 *	74.5	15,580 *		
45	72.7	24,000 *	77.0	19,060 *	75.2	24,000 *			60	70.5	16,510 *	76.7	10,730 *	72.5	14,410 *	79.5	9,100 *
50	70.2	24,000 *	74.4	18,120 *	72.9	23,320 *	78.2	14,810 *	65	68.3	15,380 *	74.4	10,250 *	70.5	13,400 *	77.4	8,660 *
55	67.5	23,690	71.6	17,210 *	70.4	21,400 *	75.6	14,020 *	70	66.1	14,390 *	72.0	9,780 *	68.4	12,520 *	75.3	8,240 *
60	64.9	21,120	68.9	16,460 *	68.1	19,880 *	73.2	13,330 *	75	63.6	13,490 *	69.5	9,360 *	66.1	11,680 *	72.9	7,870 *
65	62.2	19,000	66.1	15,800 *	65.6	18,560 *	70.7	12,760 *	80	61.3	12,720 *	67.0	8,990 *	64.0	11,000 *	70.7	7,530 *
70	59.4	17,190	63.3	15,210 *	63.2	17,370	68.1	12,230 *	85	58.8	12,050 *	64.5	8,680 *	61.8	10,400 *	68.4	7,230 *
75	56.4	15,560	60.2	14,660 *	60.4	15,740	65.3	11,720 *	90	56.3	11,440 *	61.8	8,370 *	59.5	9,850 *	66.0	6,960 *
80	53.5	14,240	57.1	14,190 *	57.8	14,410	62.5	11,300 *	95	53.6	10,860 *	58.9	8,110 *	57.1	9,320 *	63.4	6,700 *
85	50.4	13,090	53.9	13,330	55.1	13,240	59.7	10,930 *	100	50.9	10,380 *	56.1	7,870 *	54.7	8,880 *	60.9	6,480 *
90	47.1	12,100			52.3	12,230	56.7	10,580 *	105	48.0	9,850	53.1	7,640 *	52.2	8,480 *	58.3	6,280 *
95	43.4	11,150			49.1	11,280	53.4	10,270 *	110	45.0	9,210			49.6	8,110 *	55.5	6,100 *
100	39.7	10,360			46.0	10,490			115	41.7	8,570			46.7	7,760 *	52.4	5,930 *
105	35.6	9,650			42.7	9,760			120	38.2	8,040			43.8	7,450 *		
110					39.1	9,120			125	34.4	7,560			40.7	7,180 *		
115					35.0	8,500			130					37.4	6,940 *		
									135					33.8	6,720 *		

CK850-III Jib Rated Loads in Pounds

2 Counterweights + 2 Low Weights - Crawlers fully extended

100' Boom									100' Boom								
Load Radius (ft.)	30' Jib				40' Jib				Load Radius (ft.)	50' Jib				60' Jib			
	10° Offset		30° Offset		10° Offset		30° Offset			10° Offset		30° Offset		10° Offset		30° Offset	
	Boom Angle (deg.)	Rated Load (lbs.)	Boom Angle (deg.)	Rated Load (lbs.)	Boom Angle (deg.)	Rated Load (lbs.)	Boom Angle (deg.)	Rated Load (lbs.)		Boom Angle (deg.)	Rated Load (lbs.)	Boom Angle (deg.)	Rated Load (lbs.)	Boom Angle (deg.)	Rated Load (lbs.)	Boom Angle (deg.)	Rated Load (lbs.)
32	79.9	24,000 *							40	79.9	20,000 *						
34	79.0	24,000 *							45	78.0	20,000 *			79.3	18,000 *		
36	78.1	24,000 *			80.0	24,000 *			50	76.0	20,000 *			77.5	17,680 *		
38	77.2	24,000 *			79.2	24,000 *			55	73.9	18,580 *	79.7	11,500 *	75.5	16,200 *		
40	76.4	24,000 *			78.4	24,000 *			60	71.9	17,260 *	77.7	10,950 *	73.7	15,030 *		
45	74.1	24,000 *	78.0	19,480 *	76.3	24,000 *			65	69.9	16,110 *	75.5	10,470 *	71.8	13,990 *	78.3	8,810 *
50	71.8	24,000 *	75.7	18,560 *	74.2	24,000 *	79.1	15,100 *	70	67.8	15,120 *	73.4	10,030 *	69.9	13,090 *	76.3	8,420 *
55	69.3	23,450	73.2	17,650 *	71.9	22,480 *	76.7	14,320 *	75	65.6	14,170 *	71.1	9,610 *	67.8	12,250 *	74.2	8,040 *
60	67.0	20,870	70.7	16,930 *	69.7	20,920 *	74.5	13,660 *	80	63.4	13,380 *	68.8	9,230 *	65.8	11,550 *	72.1	7,710 *
65	64.5	18,730	68.2	16,260 *	67.5	18,950	72.2	13,090 *	85	61.2	12,690 *	66.5	8,920 *	63.8	10,910 *	70.0	7,420 *
70	62.1	16,930	65.7	15,670 *	65.3	17,150	69.9	12,560 *	90	59.0	12,050 *	64.2	8,610 *	61.7	10,360 *	67.9	7,160 *
75	59.4	15,290	62.9	15,100 *	62.8	15,490	67.3	12,050 *	95	56.5	11,130	61.6	8,330 *	59.5	9,810 *	65.5	6,900 *
80	56.7	13,970	60.2	14,300	60.4	14,150	64.9	11,640 *	100	54.1	10,310	59.1	8,090 *	57.3	9,340 *	63.2	6,670 *
85	54.0	12,830	57.4	13,110	58.0	13,000	62.4	11,260 *	105	51.6	9,590	56.4	7,870 *	55.1	8,920 *	60.9	6,450 *
90	51.2	11,810	54.5	12,050	55.5	11,970	59.8	10,910 *	110	49.0	8,950	53.7	7,690 *	52.7	8,550 *	58.4	6,280 *
95	48.1	10,860	51.2	11,060	52.8	11,020	56.9	10,580 *	115	46.1	8,310			50.2	8,170 *	55.7	6,100 *
100	45.0	10,070			50.1	10,200	54.0	10,310 *	120	43.2	7,780			47.7	7,820	53.1	5,950 *
105	41.7	9,360			47.2	9,500			125	40.2	7,290			45.1	7,340		
110	38.1	8,730			44.3	8,860			130	36.8	6,830			42.3	6,870		
115	34.0	8,130			40.9	8,220			135	33.2	6,430			39.4	6,480		
120					37.4	7,690			140					35.9	6,060		
125					33.7	7,230			145					32.4	5,730		

110' Boom									110' Boom								
Load Radius (ft.)	30' Jib				40' Jib				Load Radius (ft.)	50' Jib				60' Jib			
	10° Offset		30° Offset		10° Offset		30° Offset			10° Offset		30° Offset		10° Offset		30° Offset	
	Boom Angle (deg.)	Rated Load (lbs.)	Boom Angle (deg.)	Rated Load (lbs.)	Boom Angle (deg.)	Rated Load (lbs.)	Boom Angle (deg.)	Rated Load (lbs.)		Boom Angle (deg.)	Rated Load (lbs.)	Boom Angle (deg.)	Rated Load (lbs.)	Boom Angle (deg.)	Rated Load (lbs.)	Boom Angle (deg.)	Rated Load (lbs.)
34	79.8	24,000							45	78.8	20,000 *			80.0	18,000 *		
36	79.0	24,000							50	76.9	20,000 *			78.3	18,000 *		
38	78.2	24,000			79.9	24,000 *			55	75.0	19,330 *			76.4	16,820 *		
40	77.3	24,000			79.2	24,000 *			60	73.1	17,980 *	78.5	11,150 *	74.7	15,600 *		
45	75.3	24,000	79.0	19,860 *	77.2	24,000 *			65	71.2	16,820 *	76.5	10,670 *	72.9	14,570 *	79.1	8,970 *
50	73.2	24,000	76.8	18,930 *	75.3	24,000 *	79.9	15,360 *	70	69.3	15,800 *	74.6	10,250 *	71.1	13,640 *	77.2	8,570 *
55	70.9	23,320	74.5	18,070 *	73.2	23,500 *	77.7	14,610 *	75	67.2	14,830 *	72.4	9,830 *	69.2	12,780 *	75.2	8,200 *
60	68.7	20,740	72.2	17,350 *	71.2	20,960	75.6	13,970 *	80	65.2	14,020 *	70.4	9,470 *	67.3	12,050 *	73.3	7,890 *
65	66.5	18,580	70.0	16,680 *	69.1	18,800	73.5	13,400 *	85	63.2	12,960	68.3	9,140 *	65.5	11,410 *	71.4	7,580 *
70	64.3	16,770	67.7	16,090 *	67.1	16,970	71.4	12,870 *	90	61.2	11,920	66.1	8,840 *	63.6	10,840 *	69.4	7,310 *
75	61.8	15,140	65.1	15,520 *	64.8	15,340	69.1	12,380 *	95	58.9	10,950	63.8	8,550 *	61.5	10,270 *	67.2	7,050 *
80	59.4	13,820	62.7	14,170	62.7	13,990	66.9	11,940 *	100	56.7	10,160	61.5	8,310 *	59.5	9,780 *	65.2	6,830 *
85	57.0	12,670	60.2	12,980	60.5	12,830	64.6	11,570 *	105	54.5	9,430	59.2	8,090 *	57.5	9,360 *	63.0	6,630 *
90	54.5	11,660	57.6	11,920	58.2	11,810	62.2	11,220 *	110	52.2	8,770	56.7	7,890 *	55.4	8,840	60.9	6,430 *
95	51.8	10,710	54.8	10,930	55.7	10,840	59.7	10,890 *	115	49.7	8,130	54.0	7,690 *	53.1	8,200	58.4	6,260 *
100	49.1	9,920	52.0	10,110	53.3	10,050	57.1	10,470	120	47.2	7,600			50.9	7,640	56.1	6,100 *
105	46.3	9,210			50.8	9,320	54.5	9,700	125	44.5	7,120			48.6	7,160	53.6	5,970 *
110	43.3	8,570			48.2	8,680	51.8	9,010	130	41.8	6,650			46.2	6,700		
115	39.9	7,950			45.4	8,040			135	38.8	6,260			43.6	6,300		
120	36.5	7,420			42.5	7,510			140	35.4	5,860			40.8	5,880		
125	32.7	6,960			39.4	7,050			145					37.9	5,530		
130					36.1	6,610			150					34.8	5,220		
135					32.5	6,190											

CK850-III Jib Rated Loads in Pounds

2 Counterweights + 2 Low Weights - Crawlers fully extended

120' Boom									120' Boom								
Load Radius (ft.)	30' Jib				40' Jib				Load Radius (ft.)	50' Jib				60' Jib			
	10° Offset		30° Offset		10° Offset		30° Offset			10° Offset		30° Offset		10° Offset		30° Offset	
	Boom Angle (deg.)	Rated Load (lbs.)	Boom Angle (deg.)	Rated Load (lbs.)	Boom Angle (deg.)	Rated Load (lbs.)	Boom Angle (deg.)	Rated Load (lbs.)		Boom Angle (deg.)	Rated Load (lbs.)	Boom Angle (deg.)	Rated Load (lbs.)	Boom Angle (deg.)	Rated Load (lbs.)	Boom Angle (deg.)	Rated Load (lbs.)
36	79.7	24,000 *							45	79.5	20,000 *						
38	79.0	24,000 *							50	77.7	20,000 *			78.9	18,000 *		
40	78.2	24,000 *			79.9	24,000 *			55	75.9	20,000 *			77.2	17,390 *		
45	76.3	24,000 *	79.7	20,190 *	78.1	24,000 *			60	74.2	18,690 *	79.2	11,330 *	75.6	16,180 *		
50	74.3	24,000 *	77.7	19,290 *	76.2	24,000 *			65	72.4	17,500 *	77.4	10,860 *	73.9	15,120 *	79.7	9,080 *
55	72.2	23,100	75.6	18,450 *	74.3	23,360	78.5	14,880 *	70	70.6	16,440 *	75.6	10,420 *	72.2	14,170 *	78.0	8,700 *
60	70.2	20,520	73.5	17,720 *	72.4	20,760	76.6	14,240 *	75	68.7	15,250	73.6	10,030 *	70.4	13,290 *	76.1	8,350 *
65	68.2	18,360	71.4	17,080 *	70.5	18,580	74.7	13,690 *	80	66.8	13,910	71.7	9,670 *	68.7	12,560 *	74.4	8,040 *
70	66.1	16,550	69.3	16,490 *	68.6	16,770	72.7	13,160 *	85	65.0	12,740	69.7	9,340 *	67.0	11,900 *	72.6	7,730 *
75	63.9	14,920	67.0	15,340	66.5	15,100	70.6	12,670 *	90	63.1	11,700	67.8	9,060 *	65.2	11,300 *	70.7	7,470 *
80	61.7	13,600	64.8	13,970	64.5	13,770	68.5	12,250 *	95	61.0	10,730	65.6	8,770 *	63.3	10,730 *	68.7	7,230 *
85	59.5	12,430	62.6	12,780	62.5	12,610	66.4	11,860 *	100	59.0	9,920	63.6	8,500 *	61.5	9,980	66.8	7,010 *
90	57.3	11,410	60.2	11,720	60.5	11,570	64.3	11,500 *	105	57.0	9,190	61.4	8,280 *	59.6	9,250	64.9	6,790 *
95	54.8	10,470	57.7	10,730	58.2	10,620	62.0	11,130	110	54.9	8,530	59.3	8,060 *	57.7	8,590	62.9	6,610 *
100	52.4	9,650	55.2	9,890	56.0	9,810	59.7	10,290	115	52.6	7,890	56.8	7,870 *	55.6	7,950	60.7	6,410 *
105	49.9	8,950	52.6	9,140	53.8	9,080	57.4	9,520	120	50.4	7,360	54.5	7,690 *	53.6	7,400	58.6	6,260 *
110	47.3	8,310			51.5	8,440	55.0	8,840	125	48.1	6,850	52.1	7,250	51.5	6,920	56.4	6,100 *
115	44.5	7,690			49.0	7,800	52.3	8,150	130	45.7	6,410			49.3	6,450	54.1	5,970 *
120	41.6	7,160			46.5	7,270			135	43.1	5,990			47.1	6,040	51.7	5,860 *
125	38.5	6,670			43.8	6,790			140	40.3	5,590			44.6	5,640		
130	35.3	6,230			41.1	6,320			145	37.4	5,240			42.2	5,290		
135	31.7	5,840			38.1	5,930			150	34.3	4,910			39.6	4,960		
140					34.7	5,530			155					36.8	4,650		
									160					33.6	4,340		

130' Boom									130' Boom								
Load Radius (ft.)	30' Jib				40' Jib				Load Radius (ft.)	50' Jib				60' Jib			
	10° Offset		30° Offset		10° Offset		30° Offset			10° Offset		30° Offset		10° Offset		30° Offset	
	Boom Angle (deg.)	Rated Load (lbs.)	Boom Angle (deg.)	Rated Load (lbs.)	Boom Angle (deg.)	Rated Load (lbs.)	Boom Angle (deg.)	Rated Load (lbs.)		Boom Angle (deg.)	Rated Load (lbs.)	Boom Angle (deg.)	Rated Load (lbs.)	Boom Angle (deg.)	Rated Load (lbs.)	Boom Angle (deg.)	Rated Load (lbs.)
38	79.7	24,000 *							45	80.0	20,000 *						
40	79.0	24,000 *							50	78.4	20,000 *			79.5	18,000 *		
45	77.1	24,000 *			78.8	24,000 *			55	76.7	20,000 *			77.9	17,920 *		
50	75.3	24,000 *	78.5	19,620 *	77.1	24,000 *			60	75.1	19,330 *	79.9	11,480 *	76.3	16,710 *		
55	73.4	22,880	76.5	18,780 *	75.2	23,170	79.3	15,100 *	65	73.4	18,140 *	78.2	11,020 *	74.8	15,630 *		
60	71.5	20,300	74.6	18,070 *	73.5	20,540	77.5	14,500 *	70	71.7	16,710	76.5	10,620 *	73.2	14,680 *	78.7	8,840 *
65	69.6	18,140	72.7	17,430 *	71.7	18,380	75.7	13,930 *	75	69.9	15,030	74.6	10,200 *	71.5	13,800 *	76.9	8,480 *
70	67.7	16,330	70.7	16,860	69.9	16,550	73.8	13,420 *	80	68.2	13,690	72.8	9,850 *	69.9	13,050 *	75.3	8,170 *
75	65.6	14,680	68.6	15,140	68.0	14,880	71.8	12,940 *	85	66.5	12,520	71.0	9,540 *	68.3	12,360 *	73.6	7,890 *
80	63.6	13,350	66.6	13,770	66.2	13,550	69.9	12,520 *	90	64.7	11,480	69.2	9,230 *	66.6	11,570	71.9	7,620 *
85	61.6	12,210	64.5	12,580	64.3	12,380	68.0	12,140 *	95	62.8	10,510	67.2	8,950 *	64.8	10,580	70.0	7,360 *
90	59.6	11,170	62.4	11,530	62.4	11,350	66.1	11,770 *	100	61.0	9,700	65.3	8,700 *	63.1	9,760	68.3	7,140 *
95	57.3	10,220	60.1	10,510	60.3	10,380	63.9	10,950	105	59.1	8,950	63.4	8,480 *	61.4	9,030	66.5	6,940 *
100	55.2	9,430	57.9	9,700	58.3	9,560	61.9	10,090	110	57.2	8,310	61.4	8,260 *	59.6	8,370	64.6	6,740 *
105	52.9	8,700	55.6	8,950	56.3	8,860	59.8	9,340	115	55.1	7,670	59.2	8,040 *	57.7	7,730	62.6	6,560 *
110	50.6	8,060	53.2	8,260	54.2	8,200	57.6	8,640	120	53.1	7,120	57.1	7,600	55.9	7,180	60.7	6,390 *
115	48.1	7,450			51.9	7,560	55.2	7,980	125	51.0	6,630	54.9	7,070	54.0	6,670	58.7	6,230 *
120	45.6	6,920			49.7	7,030	52.9	7,400	130	48.8	6,170	52.6	6,590	52.0	6,230	56.6	6,100 *
125	43.0	6,430			47.4	6,540			135	46.6	5,750			50.0	5,820	54.5	5,970 *
130	40.2	5,990			45.0	6,080			140	44.1	5,350			47.8	5,400	52.2	5,840
135	37.3	5,570			42.5	5,680			145	41.7	5,000			45.6	5,040		
140	33.9	5,200			39.6	5,260			150	39.1	4,670			43.3	4,710		
145					36.8	4,930			155	36.3	4,360			41.0	4,400		
150					33.7	4,600			160	33.1	4,030			38.3	4,070		
									165					35.6	3,760		
									170					32.7	3,480		

CK850-III Jib Rated Loads in Pounds

2 Counterweights + 2 Low Weights - Crawlers fully extended

140' Boom									140' Boom								
Load Radius (ft.)	30' Jib				40' Jib				Load Radius (ft.)	50' Jib				60' Jib			
	10° Offset		30° Offset		10° Offset		30° Offset			10° Offset		30° Offset		10° Offset		30° Offset	
	Boom Angle (deg.)	Rated Load (lbs.)	Boom Angle (deg.)	Rated Load (lbs.)	Boom Angle (deg.)	Rated Load (lbs.)	Boom Angle (deg.)	Rated Load (lbs.)		Boom Angle (deg.)	Rated Load (lbs.)	Boom Angle (deg.)	Rated Load (lbs.)	Boom Angle (deg.)	Rated Load (lbs.)	Boom Angle (deg.)	Rated Load (lbs.)
40	79.6	24,000 *							50	79.1	20,000 *						
45	77.9	24,000 *			79.4	24,000 *			55	77.4	20,000 *			78.5	18,000 *		
50	76.2	24,000 *	79.2	19,900 *	77.8	24,000 *			60	75.9	19,970 *			77.0	17,210 *		
55	74.4	22,680	77.4	19,090 *	76.1	22,970	79.9	15,320 *	65	74.3	18,360	78.8	11,170 *	75.6	16,130 *		
60	72.6	20,080	75.6	18,400 *	74.4	20,340	78.2	14,720 *	70	72.8	16,510	77.2	10,780 *	74.1	15,160 *	79.3	8,950 *
65	70.9	17,940	73.8	17,760 *	72.8	18,180	76.5	14,170 *	75	71.1	14,830	75.5	10,380 *	72.5	14,260 *	77.7	8,590 *
70	69.1	16,110	72.0	16,680	71.1	16,330	74.8	13,690 *	80	69.4	13,490	73.8	10,030 *	71.0	13,490 *	76.1	8,310 *
75	67.2	14,460	70.0	14,960	69.3	14,680	72.9	13,180 *	85	67.8	12,300	72.1	9,720 *	69.4	12,410	74.5	8,020 *
80	65.3	13,130	68.1	13,600	67.6	13,330	71.2	12,760 *	90	66.2	11,260	70.4	9,430 *	67.9	11,350	72.9	7,760 *
85	63.5	11,970	66.2	12,380	65.9	12,160	69.4	12,380 *	95	64.4	10,290	68.6	9,120 *	66.2	10,380	71.2	7,510 *
90	61.6	10,950	64.3	11,330	64.1	11,130	67.6	11,810	100	62.7	9,470	66.8	8,880 *	64.6	9,540	69.5	7,270 *
95	59.5	9,980	62.2	10,310	62.2	10,160	65.6	10,780	105	60.9	8,730	65.0	8,660 *	63.0	8,810	67.8	7,070 *
100	57.5	9,190	60.1	9,500	60.3	9,340	63.7	9,920	110	59.2	8,060	63.2	8,440 *	61.4	8,150	66.1	6,870 *
105	55.5	8,460	58.1	8,750	58.5	8,610	61.8	9,140	115	57.2	7,420	61.2	8,000	59.6	7,490	64.3	6,700 *
110	53.4	7,820	55.9	8,060	56.6	7,950	59.8	8,460	120	55.4	6,900	59.3	7,420	57.9	6,960	62.5	6,520 *
115	51.1	7,180	53.5	7,400	54.5	7,340	57.6	7,780	125	53.5	6,390	57.3	6,900	56.1	6,450	60.7	6,370 *
120	48.9	6,650	51.3	6,850	52.5	6,790	55.5	7,200	130	51.6	5,930	55.3	6,390	54.3	5,990	58.8	6,230 *
125	46.6	6,170			50.4	6,300	53.4	6,670	135	49.5	5,510	53.1	5,950	52.5	5,570	56.9	6,100 *
130	44.2	5,730			48.2	5,840			140	47.3	5,090			50.5	5,150	54.7	5,640
135	41.7	5,330			46.0	5,420			145	45.1	4,730			48.5	4,800	52.7	5,240
140	38.8	4,910			43.5	5,020			150	42.9	4,400			46.5	4,470		
145	36.0	4,560			41.1	4,670			155	40.5	4,030			44.4	4,100		
150	32.9	4,210			38.5	4,320			160	37.8	3,680			42.0	3,720		
155					35.7	3,940			165	35.1	3,370			39.7	3,410		
160					32.5	3,610			170	32.2	3,080			37.3	3,130		
									175					34.6	2,840		

150' Boom									150' Boom								
Load Radius (ft.)	30' Jib				40' Jib				Load Radius (ft.)	50' Jib				60' Jib			
	10° Offset		30° Offset		10° Offset		30° Offset			10° Offset		30° Offset		10° Offset		30° Offset	
	Boom Angle (deg.)	Rated Load (lbs.)	Boom Angle (deg.)	Rated Load (lbs.)	Boom Angle (deg.)	Rated Load (lbs.)	Boom Angle (deg.)	Rated Load (lbs.)		Boom Angle (deg.)	Rated Load (lbs.)	Boom Angle (deg.)	Rated Load (lbs.)	Boom Angle (deg.)	Rated Load (lbs.)	Boom Angle (deg.)	Rated Load (lbs.)
45	78.6	24,000 *			80.0	24,000 *			50	79.6	20,000 *						
50	77.0	24,000 *	79.9	20,170 *	78.5	24,000 *			55	78.1	20,000 *			79.1	18,000 *		
55	75.3	22,530	78.1	19,370 *	76.8	22,810			60	76.6	20,000 *			77.7	17,700 *		
60	73.6	19,920	76.4	18,690 *	75.3	20,190	78.9	14,920 *	65	75.1	18,200	79.4	11,330 *	76.3	16,600 *		
65	72.0	17,790	74.8	18,070 *	73.7	18,030	77.3	14,390 *	70	73.7	16,350	77.9	10,930 *	74.9	15,650 *	79.9	9,060 *
70	70.3	15,960	73.1	16,550	72.1	16,180	75.7	13,910 *	75	72.1	14,680	76.3	10,530 *	73.4	14,720 *	78.3	8,700 *
75	68.5	14,300	71.2	14,830	70.5	14,520	73.9	13,420 *	80	70.5	13,330	74.7	10,200 *	71.9	13,420	76.8	8,420 *
80	66.8	12,980	69.5	13,470	68.8	13,180	72.3	13,000 *	85	69.0	12,140	73.1	9,870 *	70.5	12,230	75.3	8,130 *
85	65.1	11,810	67.7	12,250	67.2	12,010	70.6	12,630 *	90	67.5	11,110	71.5	9,590 *	69.0	11,190	73.8	7,890 *
90	63.3	10,800	65.9	11,190	65.6	10,970	68.9	11,680	95	65.8	10,110	69.8	9,300 *	67.4	10,200	72.2	7,620 *
95	61.4	9,830	63.9	10,180	63.8	10,000	67.1	10,670	100	64.2	9,300	68.2	9,060 *	65.9	9,390	70.6	7,400 *
100	59.6	9,010	62.1	9,340	62.1	9,190	65.3	9,810	105	62.6	8,570	66.5	8,810 *	64.4	8,640	69.1	7,200 *
105	57.7	8,310	60.2	8,590	60.4	8,460	63.5	9,030	110	60.9	7,910	64.8	8,570	62.9	7,980	67.5	7,010 *
110	55.8	7,640	58.2	7,910	58.6	7,800	61.7	8,330	115	59.1	7,270	62.9	7,890	61.2	7,340	65.7	6,830 *
115	53.7	7,030	56.1	7,270	56.7	7,160	59.7	7,670	120	57.4	6,720	61.2	7,290	59.6	6,790	64.1	6,650 *
120	51.7	6,500	54.0	6,700	54.8	6,610	57.8	7,090	125	55.7	6,210	59.3	6,760	58.0	6,280	62.4	6,500 *
125	49.6	5,990	51.8	6,190	52.9	6,120	55.8	6,560	130	53.9	5,750	57.5	6,280	56.3	5,820	60.7	6,370 *
130	47.5	5,550			51.0	5,660	53.8	6,080	135	52.0	5,330	55.6	5,820	54.6	5,400	58.9	5,970
135	45.3	5,150			49.0	5,260			140	50.0	4,930	53.4	5,350	52.8	4,980	57.0	5,530
140	42.8	4,730			46.7	4,850			145	48.1	4,560			51.0	4,620	55.1	5,130
145	40.3	4,320			44.6	4,450			150	46.1	4,160			49.2	4,230	53.1	4,760
150	37.8	3,940			42.3	4,050			155	43.9	3,790			47.3	3,850		
155	35.0	3,590			39.9	3,700			160	41.6	3,430			45.2	3,480		
160	31.8	3,260			37.3	3,350			165	39.3	3,100			43.1	3,170		
165					34.6	3,040			170	36.8	2,820			41.0	2,860		
									175	34.2	2,550			38.7	2,600		

CK850-III Jib Rated Loads in Pounds

2 Counterweights + 2 Low Weights - Crawlers fully extended

160' Boom									160' Boom								
Load Radius (ft.)	30' Jib				40' Jib				Load Radius (ft.)	50' Jib				60' Jib			
	10° Offset		30° Offset		10° Offset		30° Offset			10° Offset		30° Offset		10° Offset		30° Offset	
	Boom Angle (deg.)	Rated Load (lbs.)	Boom Angle (deg.)	Rated Load (lbs.)	Boom Angle (deg.)	Rated Load (lbs.)	Boom Angle (deg.)	Rated Load (lbs.)		Boom Angle (deg.)	Rated Load (lbs.)	Boom Angle (deg.)	Rated Load (lbs.)	Boom Angle (deg.)	Rated Load (lbs.)	Boom Angle (deg.)	Rated Load (lbs.)
45	79.2	24,000 *							55	78.7	20,000 *			79.6	18,000 *		
50	77.7	24,000 *			79.0	22,830 *			60	77.3	19,200 *			78.3	17,800 *		
55	76.1	22,350	78.8	19,640 *	77.5	22,000 *			65	75.9	18,030	80.0	11,440 *	76.9	17,060 *		
60	74.5	19,750	77.2	18,950 *	76.0	20,030	79.5	15,120 *	70	74.5	16,180	78.5	11,060 *	75.6	16,090 *		
65	73.0	17,590	75.6	18,290	74.6	17,850	78.0	14,590 *	75	72.9	14,500	77.0	10,670 *	74.2	14,610	78.9	8,810 *
70	71.4	15,760	74.0	16,400	73.1	16,000	76.4	14,100 *	80	71.5	13,130	75.5	10,330 *	72.8	13,240	77.5	8,530 *
75	69.7	14,100	72.3	14,680	71.5	14,320	74.8	13,640 *	85	70.1	11,940	74.0	10,030 *	71.4	12,050	76.1	8,240 *
80	68.1	12,780	70.7	13,290	70.0	12,980	73.2	13,220 *	90	68.6	10,910	72.5	9,740 *	70.0	11,000	74.6	8,000 *
85	66.5	11,610	69.0	12,080	68.4	11,810	71.7	12,630	95	67.0	9,920	70.9	9,450 *	68.5	10,000	73.1	7,760 *
90	64.8	10,580	67.3	11,020	66.9	10,780	70.1	11,530	100	65.5	9,100	69.3	9,210 *	67.1	9,190	71.6	7,530 *
95	63.0	9,630	65.5	10,000	65.2	9,780	68.4	10,510	105	64.0	8,370	67.8	8,970 *	65.7	8,440	70.2	7,310 *
100	61.3	8,810	63.8	9,170	63.6	8,970	66.7	9,650	110	62.5	7,690	66.2	8,420	64.2	7,780	68.7	7,140 *
105	59.6	8,090	62.0	8,420	62.0	8,240	65.1	8,880	115	60.8	7,050	64.5	7,730	62.7	7,140	67.0	6,940 *
110	57.9	7,450	60.2	7,730	60.4	7,580	63.4	8,170	120	59.2	6,500	62.8	7,140	61.2	6,590	65.5	6,790 *
115	55.9	6,810	58.2	7,070	58.6	6,940	61.5	7,490	125	57.6	6,010	61.1	6,610	59.7	6,080	63.9	6,610 *
120	54.1	6,280	56.3	6,520	56.9	6,410	59.8	6,920	130	55.9	5,550	59.4	6,100	58.1	5,620	62.3	6,280
125	52.2	5,770	54.4	5,990	55.1	5,900	58.0	6,390	135	54.2	5,130	57.6	5,640	56.5	5,180	60.7	5,820
130	50.3	5,330	52.4	5,530	53.3	5,440	56.1	5,900	140	52.4	4,670	55.7	5,200	54.8	4,760	58.9	5,350
135	48.2	4,890			51.5	5,020	54.2	5,440	145	50.6	4,250	53.8	4,800	53.2	4,320	57.1	4,960
140	46.0	4,400			49.5	4,560	52.1	5,000	150	48.7	3,850	51.9	4,430	51.5	3,920	55.4	4,580
145	43.9	4,010			47.5	4,140			155	46.8	3,480			49.7	3,540	53.6	4,230
150	41.6	3,610			45.5	3,740			160	44.8	3,100			47.8	3,170	51.5	3,810
155	39.3	3,260			43.4	3,370			165	42.7	2,790			46.0	2,860		
160	36.6	2,910			41.1	3,020			170					44.1	2,550		
165	33.9	2,600			38.8	2,710											

170' Boom									170' Boom								
Load Radius (ft.)	30' Jib				40' Jib				Load Radius (ft.)	50' Jib				60' Jib			
	10° Offset		30° Offset		10° Offset		30° Offset			10° Offset		30° Offset		10° Offset		30° Offset	
	Boom Angle (deg.)	Rated Load (lbs.)	Boom Angle (deg.)	Rated Load (lbs.)	Boom Angle (deg.)	Rated Load (lbs.)	Boom Angle (deg.)	Rated Load (lbs.)		Boom Angle (deg.)	Rated Load (lbs.)	Boom Angle (deg.)	Rated Load (lbs.)	Boom Angle (deg.)	Rated Load (lbs.)	Boom Angle (deg.)	Rated Load (lbs.)
45	79.8	23,360 *							55	79.2	18,500 *			80.0	17,000 *		
50	78.3	22,830 *			79.6	20,800 *			60	77.9	17,800 *			78.8	16,400 *		
55	76.8	22,150	79.4	19,860 *	78.1	20,000 *			65	76.5	17,100 *			77.5	15,800 *		
60	75.3	19,550	77.9	19,220 *	76.7	19,200 *	80.0	15,290 *	70	75.2	15,980	79.1	11,170 *	76.2	15,200 *		
65	73.8	17,370	76.4	18,120	75.3	17,630	78.6	14,770 *	75	73.8	14,280	77.6	10,800 *	74.9	13,980 *	79.4	8,900 *
70	72.4	15,560	74.9	16,220	73.9	15,800	77.1	14,300 *	80	72.4	12,940	76.2	10,490 *	73.6	13,050	78.1	8,610 *
75	70.8	13,880	73.2	14,500	72.4	14,130	75.6	13,840 *	85	71.0	11,750	74.8	10,180 *	72.3	11,860	76.7	8,350 *
80	69.3	12,560	71.7	13,090	71.0	12,760	74.1	13,420 *	90	69.6	10,690	73.4	9,890 *	71.0	10,800	75.4	8,110 *
85	67.7	11,390	70.1	11,880	69.5	11,590	72.6	12,450	95	68.2	9,720	71.9	9,610 *	69.5	9,810	73.9	7,870 *
90	66.2	10,360	68.6	10,820	68.1	10,560	71.1	11,370	100	66.7	8,880	70.4	9,360 *	68.2	8,970	72.5	7,640 *
95	64.5	9,390	66.9	9,810	66.5	9,560	69.5	10,330	105	65.3	8,150	68.9	8,970	66.8	8,220	71.1	7,450 *
100	62.9	8,590	65.2	8,970	65.0	8,750	68.0	9,470	110	63.9	7,470	67.4	8,240	65.5	7,560	69.7	7,250 *
105	61.3	7,870	63.6	8,220	63.5	8,020	66.4	8,680	115	62.3	6,830	65.8	7,560	64.0	6,920	68.2	7,050 *
110	59.7	7,200	61.9	7,530	61.9	7,360	64.8	8,000	120	60.8	6,280	64.3	6,960	62.6	6,340	66.7	6,900 *
115	57.9	6,560	60.1	6,870	60.3	6,720	63.1	7,310	125	59.3	5,770	62.7	6,410	61.1	5,860	65.2	6,610
120	56.2	6,040	58.3	6,300	58.7	6,170	61.5	6,720	130	57.7	5,310	61.1	5,930	59.7	5,370	63.7	6,100
125	54.4	5,550	56.5	5,790	57.0	5,680	59.8	6,190	135	56.1	4,870	59.5	5,460	58.2	4,960	62.2	5,640
130	52.6	5,070	54.7	5,310	55.4	5,220	58.1	5,700	140	54.4	4,360	57.7	5,000	56.6	4,450	60.5	5,180
135	50.8	4,560	52.8	4,850	53.7	4,730	56.4	5,260	145	52.8	3,920	56.0	4,620	55.1	4,010	58.9	4,780
140	48.8	4,070			51.8	4,230	54.4	4,820	150	51.1	3,520	54.2	4,160	53.5	3,610	57.3	4,380
145	46.9	3,650			50.1	3,810	52.6	4,360	155	49.3	3,150	52.4	3,760	51.9	3,240	55.6	3,960
150	44.8	3,280			48.2	3,410			160	47.4	2,790			50.2	2,860	53.8	3,540
155	42.7	2,930			46.3	3,060			165					48.5	2,530	52.0	3,170
160	40.4	2,570			44.2	2,680											

CK850-III Jib Rated Loads in Pounds

2 Counterweights + 2 Low Weights - Crawlers fully extended

180' Boom									180' Boom								
Load Radius (ft.)	30' Jib				40' Jib				Load Radius (ft.)	50' Jib				60' Jib			
	10° Offset		30° Offset		10° Offset		30° Offset			10° Offset		30° Offset		10° Offset		30° Offset	
	Boom Angle (deg.)	Rated Load (lbs.)	Boom Angle (deg.)	Rated Load (lbs.)	Boom Angle (deg.)	Rated Load (lbs.)	Boom Angle (deg.)	Rated Load (lbs.)		Boom Angle (deg.)	Rated Load (lbs.)	Boom Angle (deg.)	Rated Load (lbs.)	Boom Angle (deg.)	Rated Load (lbs.)	Boom Angle (deg.)	Rated Load (lbs.)
50	78.9	19,770 *							55	79.7	17,000 *						
55	77.4	19,240 *	79.9	19,060 *	78.7	18,500 *			60	78.4	16,400 *			79.3	15,000 *		
60	76.0	18,760 *	78.5	18,580 *	77.3	17,800 *			65	77.1	15,800 *			78.0	14,500 *		
65	74.6	17,190	77.1	17,960	76.0	17,100 *	79.1	14,740 *	70	75.9	15,200 *	79.6	11,300 *	76.8	14,000 *		
70	73.2	15,360	75.6	16,070	74.7	15,630	77.7	14,460 *	75	74.5	13,980 *	78.2	10,930 *	75.5	13,500 *	79.9	8,990 *
75	71.7	13,710	74.1	14,350	73.2	13,950	76.3	14,020 *	80	73.2	12,760	76.9	10,600 *	74.3	12,870	78.6	8,700 *
80	70.3	12,360	72.6	12,940	71.9	12,580	74.9	13,580	85	71.9	11,570	75.5	10,310 *	73.0	11,680	77.3	8,460 *
85	68.8	11,190	71.2	11,720	70.5	11,410	73.5	12,320	90	70.6	10,510	74.2	10,030 *	71.8	10,620	76.0	8,200 *
90	67.4	10,180	69.7	10,640	69.1	10,360	72.1	11,220	95	69.2	9,520	72.7	9,740 *	70.4	9,630	74.6	7,950 *
95	65.8	9,190	68.1	9,630	67.6	9,390	70.5	10,180	100	67.8	8,700	71.4	9,500 *	69.2	8,790	73.3	7,760 *
100	64.3	8,390	66.5	8,790	66.2	8,570	69.1	9,320	105	66.5	7,950	70.0	8,810	67.9	8,040	72.0	7,530 *
105	62.8	7,670	65.0	8,040	64.8	7,820	67.6	8,550	110	65.1	7,290	68.5	8,110	66.6	7,360	70.7	7,360 *
110	61.3	7,010	63.4	7,360	63.3	7,160	66.1	7,840	115	63.6	6,630	67.0	7,400	65.2	6,720	69.2	7,160 *
115	59.6	6,370	61.7	6,670	61.8	6,520	64.5	7,160	120	62.2	6,080	65.6	6,810	63.8	6,170	67.8	7,010 *
120	58.0	5,840	60.1	6,120	60.3	5,970	63.0	6,560	125	60.8	5,570	64.1	6,260	62.5	5,660	66.4	6,480
125	56.4	5,310	58.4	5,590	58.8	5,460	61.4	6,040	130	59.3	5,090	62.6	5,770	61.1	5,180	65.0	5,970
130	54.7	4,780	56.7	5,110	57.2	4,960	59.8	5,550	135	57.8	4,580	61.1	5,310	59.7	4,670	63.6	5,480
135	53.0	4,270	55.0	4,580	55.6	4,450	58.2	5,090	140	56.2	4,070	59.4	4,850	58.2	4,160	62.0	5,020
140	51.2	3,790	53.1	4,070	53.9	3,940	56.4	4,580	145	54.7	3,630	57.8	4,380	56.8	3,720	60.5	4,620
145	49.4	3,370	51.3	3,610	52.3	3,520	54.7	4,120	150	53.1	3,240	56.2	3,940	55.3	3,320	59.0	4,160
150	47.6	2,970			50.6	3,130	53.0	3,680	155	51.5	2,860	54.5	3,520	53.8	2,930	57.5	3,740
155	45.7	2,600			48.8	2,750			160			52.7	3,100	52.2	2,550	55.8	3,320
									165							54.1	2,950
									170							52.4	2,600

Boom:

Welded lattice construction using tubular, high-tensile steel
Chords with pin connections between sections.

Basic boom length: 40 ft (12.2 m)

Max. boom length: 70 ft (21.3 m)

Limit on clamshell bucket weight: 4,600 lb (2,100 kg)

Optional tagline: hydraulic operated type and spring type

Boom Component Chart

Boom length ft (m)	Boom arrangement
40 (12.2)	Base-Tip
50 (15.2)	Base-A-Tip
60 (18.3)	Base-A-A-Tip, Base-B-Tip
70 (21.3)	Base-A-B-Tip

Base = Boom Base

Insert: A = 10 ft (3.05 m)

B = 20 ft (6.10 m)

C = 40 ft (12.2 m)

Tip = Boom Tip

1. Figures represent maximum allowable capacity, and assume level, ground and ideal working conditions.
2. Capacities are calculated at 66 % of the minimum tipping loads.
3. Capacities are maximum recommended by PCSA Standard #4. Allowances must be made by the user for such unfavorable conditions as a sort of uneven supporting surface, rapid cycle operations, or bucket suction.
4. The combined weight of the bucket and load must not exceed these capacities.
5. Boom length for clamshell operation should not exceed 70 ft (21.3 m).

CK850-III Clamshell Capacity in Pounds									
1 Counterweight only, No Low Weight - Crawlers fully extended									
Load Radius (ft)	40' Boom		50' Boom		Load Radius (ft)	60' Boom		70' Boom	
	Boom Angle (deg.)	360° Rated Load (lbs)	Boom Angle (deg.)	360° Rated Load (lbs)		Boom Angle (deg.)	360° Rated Load (lbs)	Boom Angle (deg.)	360° Rated Load (lbs)
22.0	63.6	16,000 *			30.0	64.5	16,000 *		
24.0	60.3	16,000 *			32.0	62.4	16,000 *		
26.0	56.9	16,000 *	64.2	16,000 *	34.0	60.2	16,000 *	64.8	16,000 *
28.0	53.4	16,000 *	61.6	16,000 *	36.0	58.0	16,000 *	63.0	16,000 *
30.0	49.7	16,000 *	58.9	16,000 *	38.0	55.7	16,000 *	61.1	16,000 *
32.0	45.7	16,000 *	56.2	16,000 *	40.0	53.3	16,000 *	59.2	16,000 *
34.0	41.5	16,000 *	53.3	16,000 *	42.0	50.9	16,000 *	57.3	16,000 *
36.0	36.9	16,000 *	50.4	16,000 *	44.0	48.3	16,000 *	55.3	15,800 *
38.0	31.6	16,000 *	47.3	16,000 *	46.0	45.7	16,000 *	53.3	15,600 *
40.0	25.5	16,000 *	44.1	16,000 *	48.0	42.9	15,200 *	51.2	15,200 *
42.0			40.6	16,000 *	50.0	40.0	14,500 *	49.0	14,300 *
44.0			36.9	16,000 *	52.0	36.9	13,600	46.8	13,600 *
46.0			32.8	16,000 *	54.0	33.5	13,000	44.5	13,000 *
48.0			28.2	15,400 *	56.0	29.8	12,300	42.1	12,300 *
					58.0	25.6	11,900	39.6	11,600 *
					60.0			36.9	11,200 *
					62.0			34.0	10,800 *
					64.0			30.9	10,100 *
					66.0			27.5	9,700 *

CK850-III

Note: Due to our policy of continual product improvement, all designs and specifications are subject to change without advance notice. Pictures inside this publication may show machines with optional equipment. This manual and the specifications herein were prepared for the market served by Kobelco Cranes North America Inc. including North America and Latin America. Kobelco product specifications in other world markets may differ.

KOBELCO CRANES CO., LTD

Oval Court Ohsaki Mark West Bldg., 17-1, Higashigotanda 2-chome,
Shinagawa-ku, Tokyo, 141-8626 JAPAN
Tel: ++81 (0) 3-5789-2130 Fax: ++81 (0) 3-5789-3372

KOBELCO CRANES NORTH AMERICA INC.

10845 Train Court
Houston Texas 77041 U.S.A
Tel: 713-856-5755 Fax: 713-856-9072
www.kobelcocranesnorthamerica.com